

PIN-IN-TORX TAMPER  
RESIST SHEET METAL SCREW 18-8 STAINLESS  
STEEL, BUTTON HEAD, NO 14 SIZE, 1-1/2" LENGTH  
NOT VISIBLE FROM FRONT OF BENCH

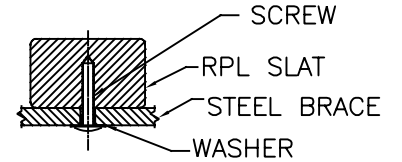

SECTION VIEW  
OF RPL BENCH SLAT WITH  
CROSS BRACE & SCREW -  
USED ON SEAT & BACK BRACES  
FROM BOTTOM & BACK OF  
BRACES - 16 REQUIRED

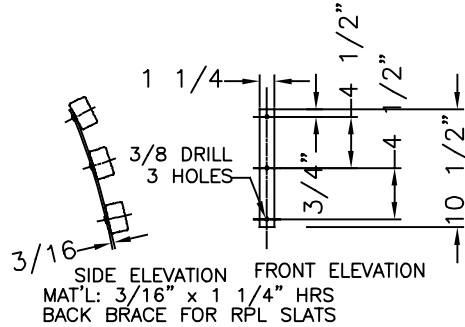
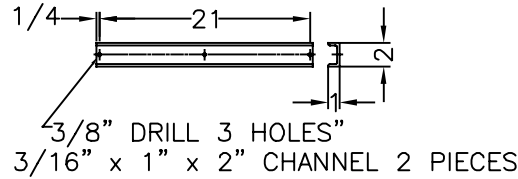
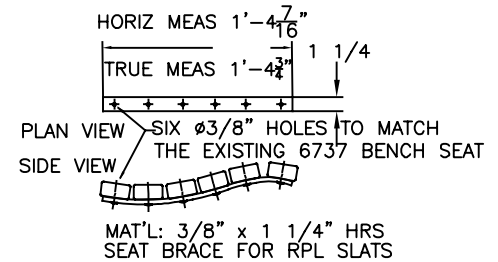
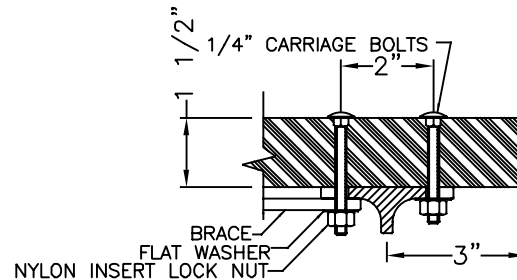
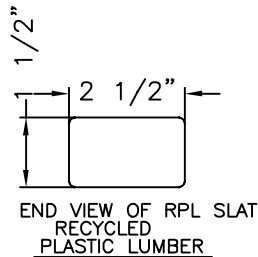
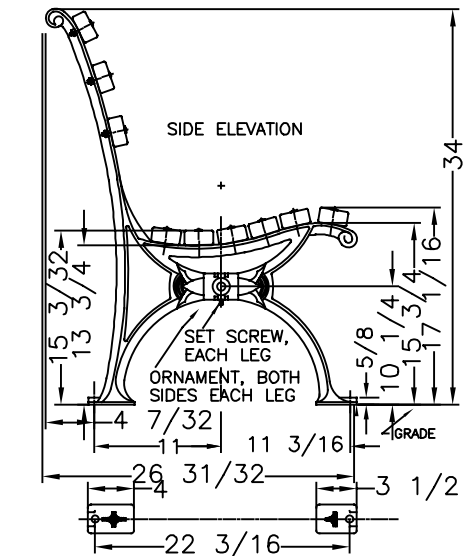

WHEN USED, ANCHOR  
BOLTS ARE TO BE  
INSTALLED IN EACH  
FOOT OF EACH LEG.

COLOR:  
RPL \_\_\_\_\_  
CI & STEEL: BLACK

MATERIALS:  
X-BRACING: 3/16" X 1 1/4" HOT ROLLED STEEL  
BENCH LEGS: CAST DUCTILE IRON  
BENCH SLATS: RPL (RECYCLED PLASTIC LUMBER)  
SMALL FASTENERS (CARRIAGE BOLTS, NUTS AND  
WASHERS), STAINLESS STEEL  
TIE ROD: 5/8" DIA HOT ROLLED STEEL WITH  
5/8 - 11 CUT THREADS & STEEL HEX NUTS  
BRACES FOR RPL: 3/16" & 3/8" x 1 1/4" HRS  
CHANNELS FOR RPL: 3/16" x 1" x 2" STEEL

**KENNETH LYNCH  
& SONS**

114 WILLENBROCK RD.  
OXFORD, CT 06478  
PH: 203-264-2831  
INFO@KLYNCHANDSONS.COM

6737C ARMLESS WORLDS FAIR BENCH		
Scale FAX	Date 6/17/22	Drawn T.J.D.
RECYCLED PLASTIC SLATS		2' LONG
2 LEGS	CONTRACT #	
6737C-2-RPL-FX-2022		