

PIN-IN-TORX TAMPER
 RESIST SHEET METAL SCREW 18-8 STAINLESS
 STEEL, BUTTON HEAD, NO 14 SIZE, 1-1/2" LENGTH
 NOT VISIBLE FROM FRONT OF BENCH

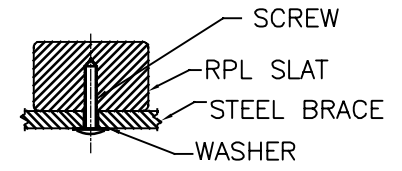

SECTION VIEW
 OF RPL BENCH SLAT WITH
 CROSS BRACE & SCREW -
 USED ON SEAT & BACK BRACES
 FROM BOTTOM & BACK OF
 BRACES - 9 REQUIRED

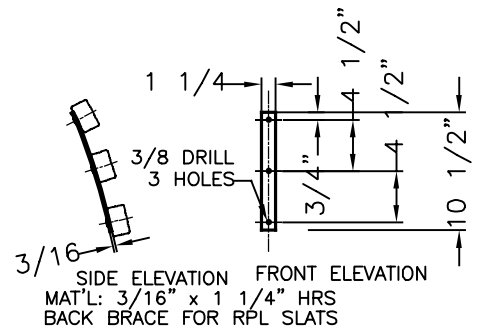
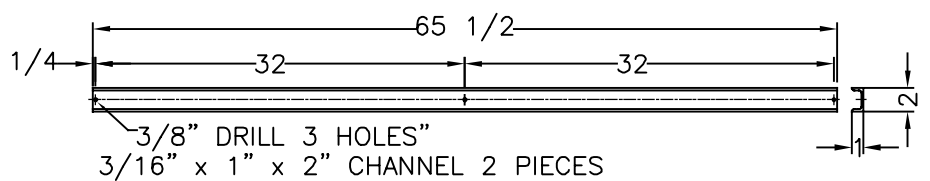
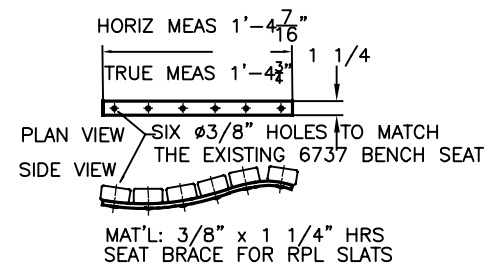
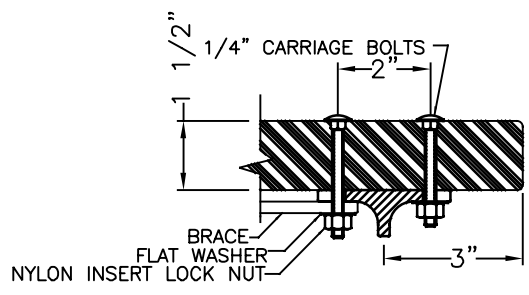
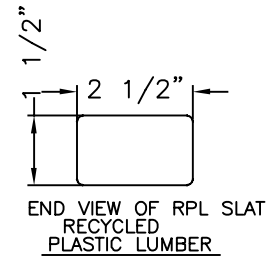
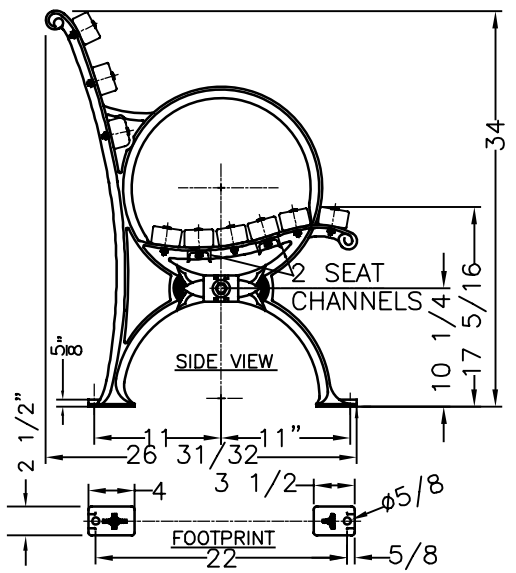

COLOR:
 RPL _____
 CI & STEEL: BLACK

MATERIALS:
 X-BRACING: 3/16" X 1 1/4" HOT ROLLED STEEL
 BENCH LEGS: CAST DUCTILE IRON
 BENCH SLATS: RPL (RECYCLED PLASTIC LUMBER)
 SMALL FASTENERS (CARRIAGE BOLTS, NUTS AND WASHERS) STAINLESS STEEL
 TIE ROD: 5/8" DIA HOT ROLLED STEEL WITH 5/8 - 11 CUT THREADS & STEEL HEX NUTS
 BRACES FOR RPL: 3/16" & 3/8" x 1 1/4" HRS
 CHANNELS FOR RPL: 3/16" x 1" x 2" STEEL

WHEN USED, ANCHOR BOLTS ARE TO BE INSTALLED IN EACH FOOT OF EACH LEG.

KENNETH LYNCH & SONS
 114 WILLENBROCK RD.
 OXFORD, CT 06478
 PH: 203-264-2831
 INFO@KLYNCHANDSONS.COM

6737 WORLDS FAIR BENCH		
Scale FAX	Date 6/10/22	Drawn T.J.D.
RECYCLED PLASTIC SLATS		6' LONG
2 LEGS	CONTRACT #	
6737-6-RPL-FX-2022		