

PIN-IN-TORX TAMPER
 RESIST SHEET METAL SCREW 18-8 STAINLESS
 STEEL, BUTTON HEAD, NO 14 SIZE, 1-1/2" LENGTH
 NOT VISIBLE FROM FRONT OF BENCH

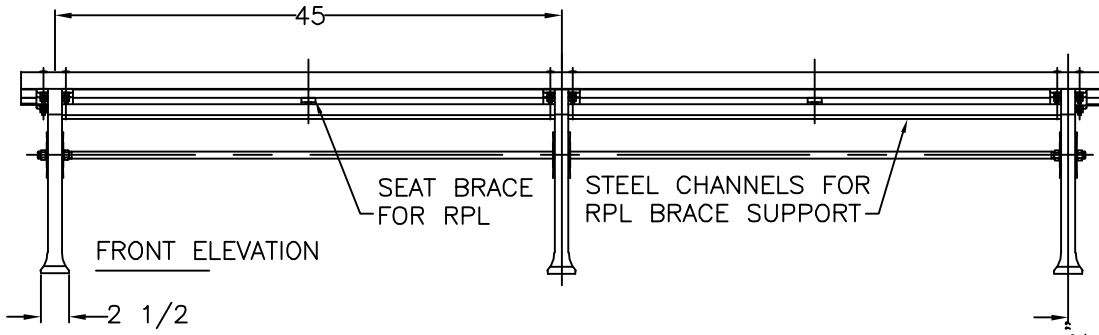

SECTION VIEW
 OF RPL BENCH SLAT WITH
 CROSS BRACE & SCREW -
 USED ON SEAT & BACK BRACES
 FROM BOTTOM & BACK OF
 BRACES - 16 REQUIRED

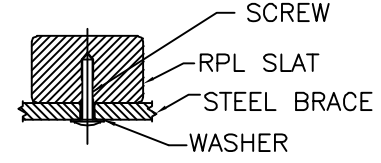
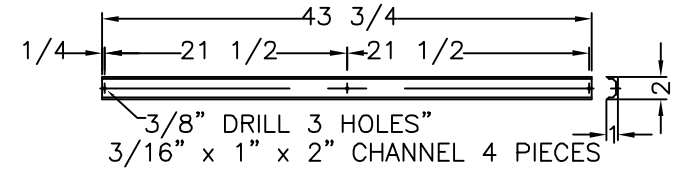
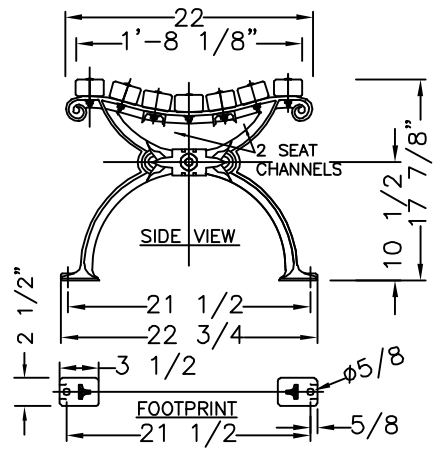
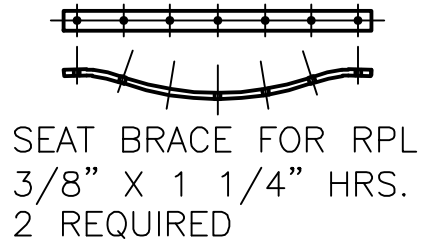
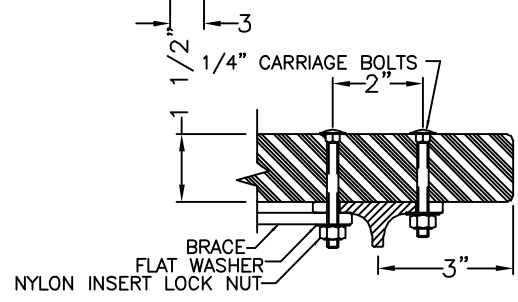
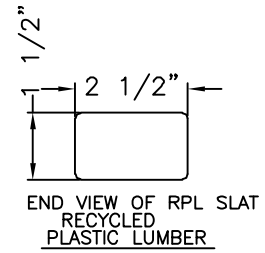

COLOR:
 RPL _____
 CI & STEEL: BLACK
 MATERIALS:
 BENCH LEGS: CAST DUCTILE IRON
 SEAT SLATS: RECYCLED PLASTIC LUMBER (RPL)
 SMALL FASTENERS (CARRIAGE BOLTS, NUTS AND
 WASHERS) STAINLESS STEEL
 TIE ROD: 5/8" DIA HOT ROLLED STEEL WITH
 5/8 - 11 CUT THREADS & STEEL HEX NUTS
 CROSS BRACE: 3/8" x 1 1/4" HOT ROLLED STEEL
 LONG BRACE: 3/16" x 1" x 2" STEEL CHANNEL

WHEN USED, ANCHOR
 BOLTS ARE TO BE
 INSTALLED IN EACH
 FOOT OF EACH LEG.

**KENNETH LYNCH
 & SONS**
 114 WILLENBROCK RD.
 OXFORD, CT 06478
 PH: 203-264-2831
 INFO@KLYNCHANDSONS.COM

6736 WORLDS FAIR BACKLESS BENCH		
Scale FAX	Date 8/18/22	Drawn T.J.D.
RECYCLED PLASTIC SLATS		8' LONG
3 LEGS	CONTRACT #	
6736-8-RPL-FX-2022		