

PIN-IN-TORX TAMPER  
RESIST SHEET METAL SCREW 18-8 STAINLESS  
STEEL, BUTTON HEAD, NO 14 SIZE, 1-1/2" LENGTH  
NOT VISIBLE FROM FRONT OF BENCH

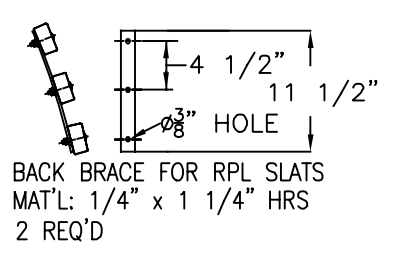
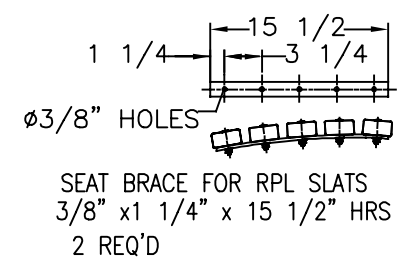
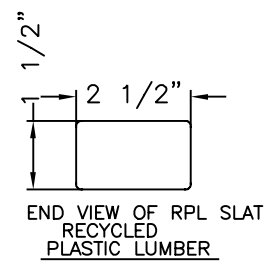
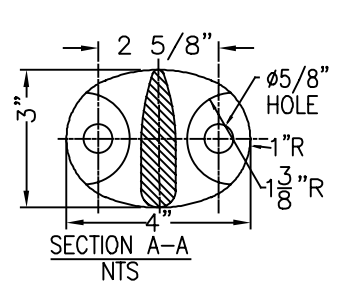
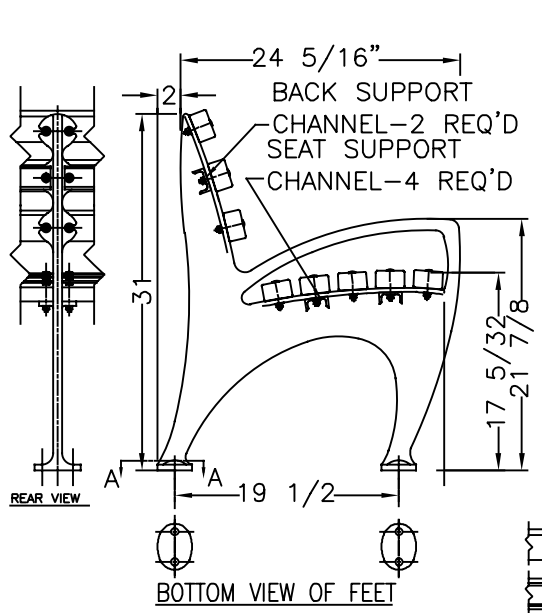
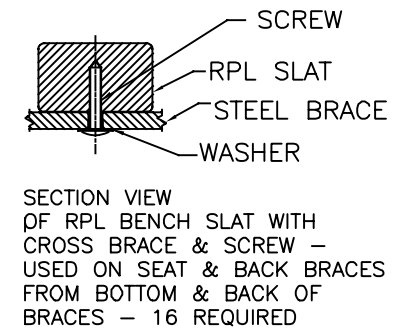
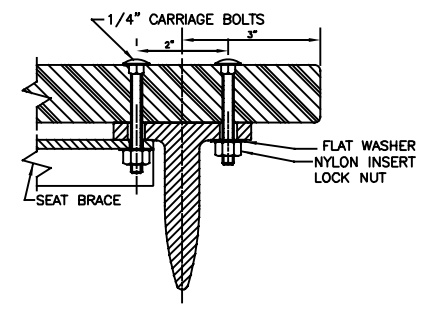
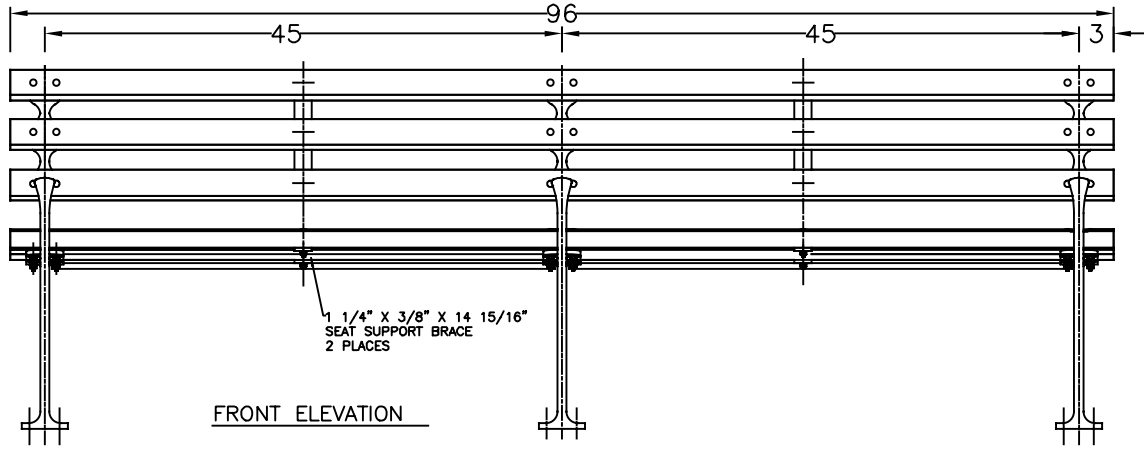
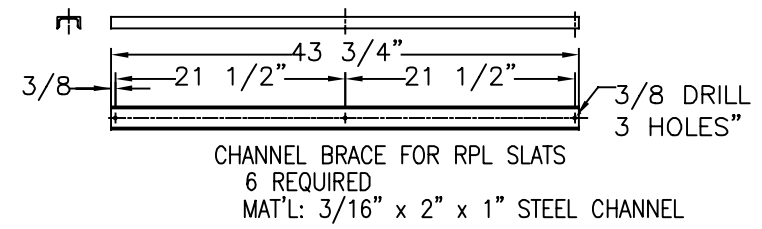

COLOR:  
RPL \_\_\_\_\_  
CI & STEEL: GALVANIZED

MATERIALS:  
BENCH LEGS: CAST DUCTILE IRON  
BENCH SLATS: RPL (RECYCLED PLASTIC LUMBER)  
SMALL FASTENERS (CARRIAGE BOLTS, NUTS,  
WASHERS & SCREWS) = STAINLESS STEEL  
BRACES FOR RPL:  
2"x1" x 3/16" STEEL CHANNEL  
3/8"x1 1/4" HRS & 1/4"x1 1/4" HRS

WHEN USED, ANCHOR  
BOLTS ARE TO BE  
INSTALLED IN EACH  
FOOT OF EACH LEG.

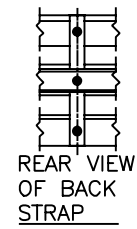

**KENNETH LYNCH  
& SONS**  
114 WILLENBROCK RD.  
OXFORD, CT 06478  
PH: 203-264-2831  
INFO@KLYNCHANDSONS.COM

<b>6733A 1964 WORLDS FAIR BENCH</b>		
Scale FAX	Date 5/13/2024	Drawn T.J.D
<b>RECYCLED PLASTIC SLATS</b>		<b>8' LONG</b>
<b>3 LEGS</b>	CONTRACT #	
<b>6733A-8-RPL-GALV-2024</b>		