

PLAN VIEW

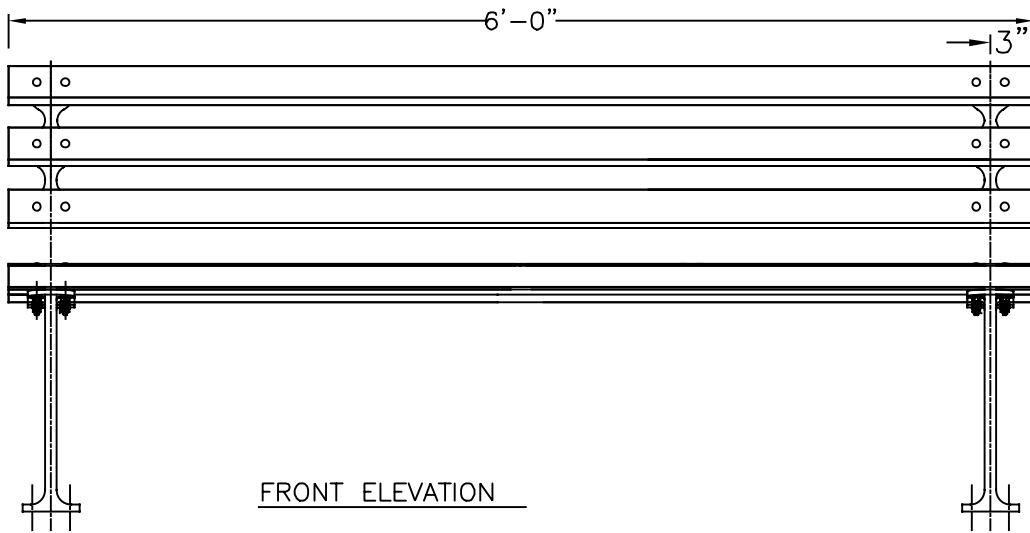

FRONT ELEVATION

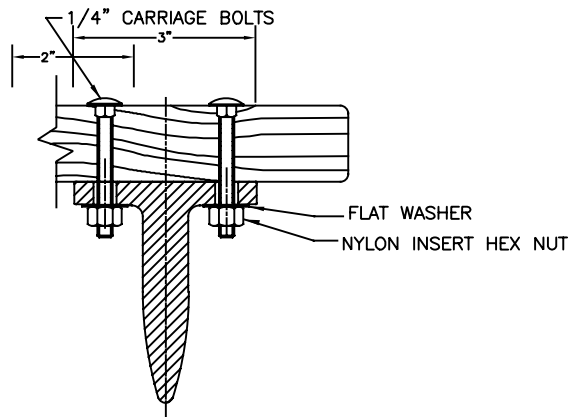

FLAT WASHER
NYLON INSERT HEX NUT

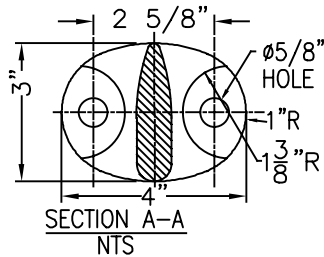

SECTION A-A
NTS

MATERIALS:
 BENCH LEGS: CAST DUCTILE IRON
 WOOD SLATS: CUMARU / DIPTERYX ODORATA
 SMALL FASTENERS (CARRIAGE BOLTS, NUTS, WASHERS & SCREWS): STAINLESS STEEL

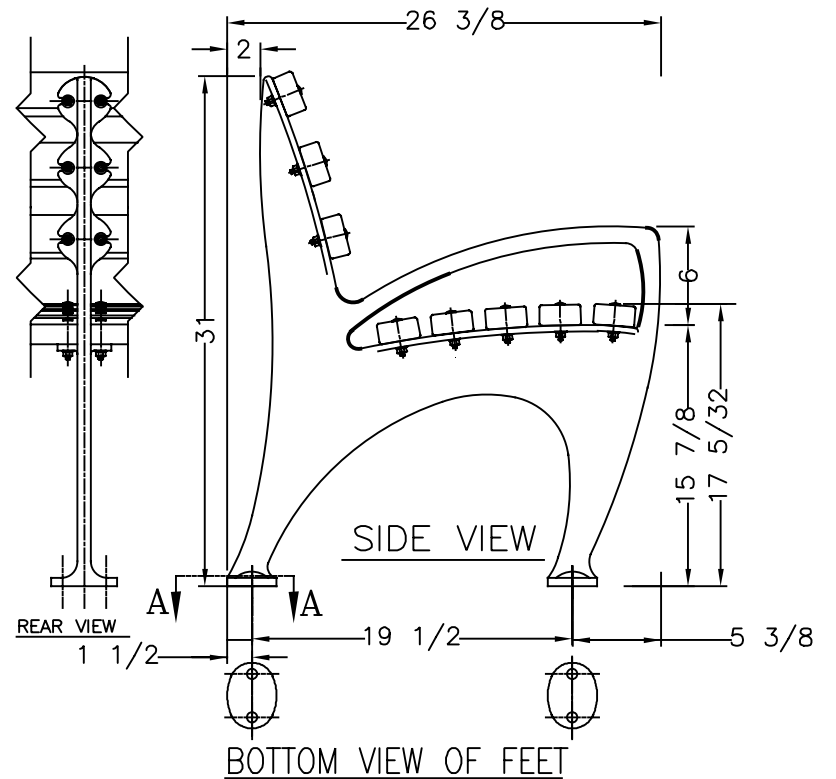

REAR VIEW

SIDE VIEW

BOTTOM VIEW OF FEET

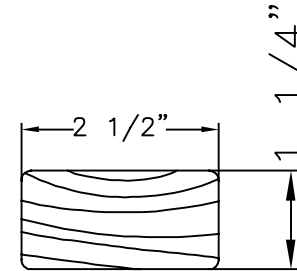

END VIEW OF WOOD SLAT

WHEN USED, ANCHOR BOLTS ARE TO BE INSTALLED IN EACH FOOT OF EACH LEG.

KENNETH LYNCH & SONS

114 WILLENBROCK RD.
 OXFORD, CT 06478
 PH: 203-264-2831
 INFO@KLYNCHANDSONS.COM

6733A 1964 WORLDS FAIR BENCH		
Scale FAX	Date 5/13/2024	Drawn T.J.D.
NATURAL CUMARU		6' LONG
2 LEGS	CONTRACT #	
6733A-6-CU-2024		