

PLAN VIEW

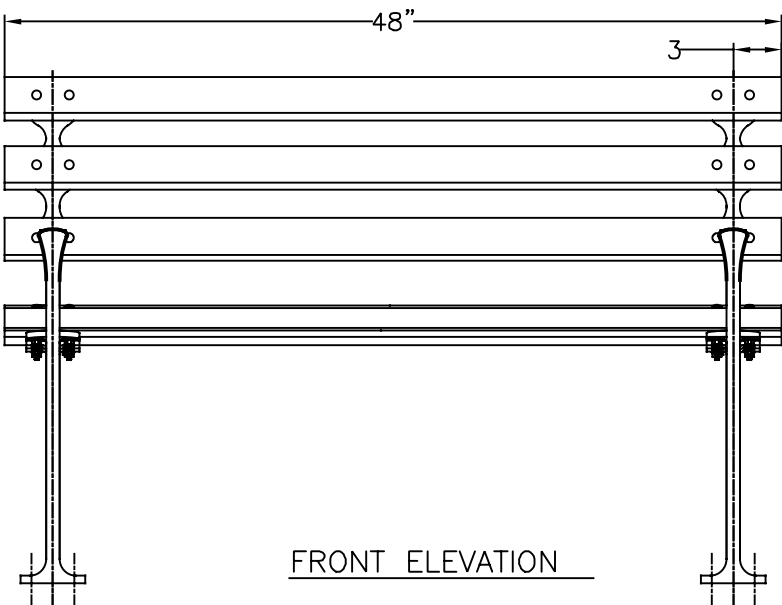

FRONT ELEVATION

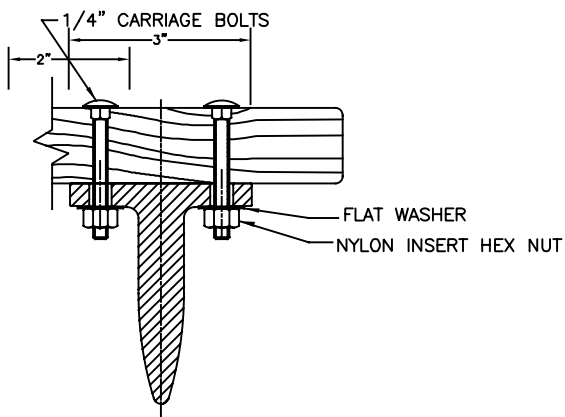

**MATERIALS:**  
 BENCH LEGS: CAST DUCTILE IRON  
 WOOD SLATS: CUMARU / DIPTERYX ODORATA  
 SMALL FASTENERS (CARRIAGE BOLTS, NUTS, WASHERS & SCREWS): STAINLESS STEEL

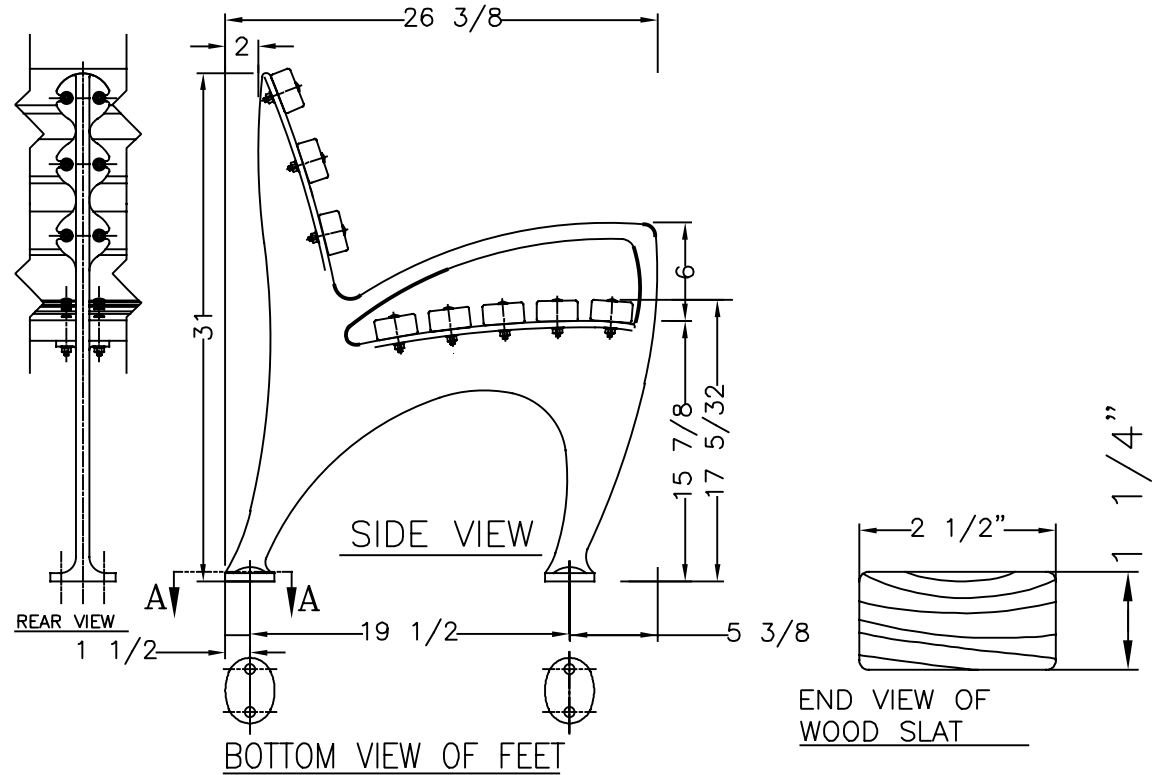

SIDE VIEW

REAR VIEW

BOTTOM VIEW OF FEET

END VIEW OF WOOD SLAT

WHEN USED, ANCHOR BOLTS ARE TO BE INSTALLED IN EACH FOOT OF EACH LEG.

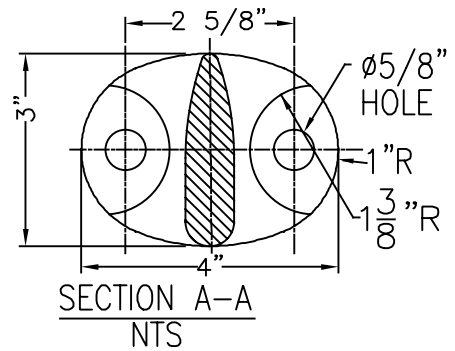

SECTION A-A  
NTS

**KENNETH LYNCH & SONS**  
 114 WILLENBROCK RD.  
 OXFORD, CT 06478  
 PH: 203-264-2831  
 INFO@KLYNCHANDSONS.COM

|                                     |                |              |
|-------------------------------------|----------------|--------------|
| <b>6733A 1964 WORLDS FAIR BENCH</b> |                |              |
| Scale FAX                           | Date 5/13/2024 | Drawn T.J.D. |
| NATURAL CUMARU                      |                | 4' LONG      |
| 2 LEGS                              | CONTRACT #     |              |
| 6733A-4-CU-2024                     |                |              |