

PIN-IN-TORX TAMPER RESIST SHEET METAL SCREW 18-8 STAINLESS STEEL, BUTTON HEAD, NO 14 SIZE, 1-1/2" LENGTH NOT VISIBLE FROM FRONT OF BENCH

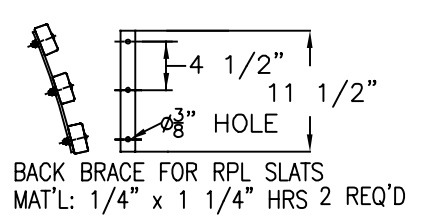

COLOR:
RPL
CI & STEEL: GALVANIZED
MATERIALS:
BENCH LEGS: CAST DUCTILE IRON
BENCH SLATS: RPL (RECYCLED PLASTIC LUMBER)
SMALL FASTENERS (CARRIAGE BOLTS, NUTS, WASHERS & SCREWS) = STAINLESS STEEL
BRACES FOR RPL:
2"x1" X 3/16" STEEL CHANNEL
3/8"x1 1/4" HRS & 1/4"x1 1/4" HRS

WHEN USED, ANCHOR BOLTS ARE TO BE INSTALLED IN EACH FOOT OF EACH LEG.

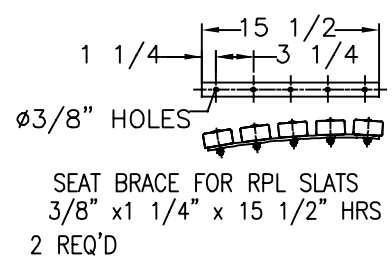
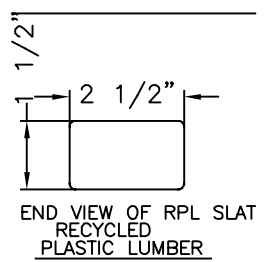
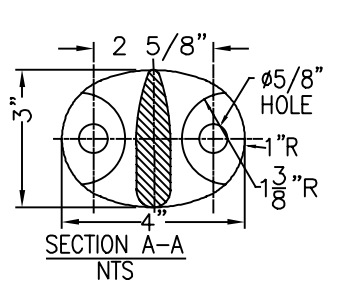
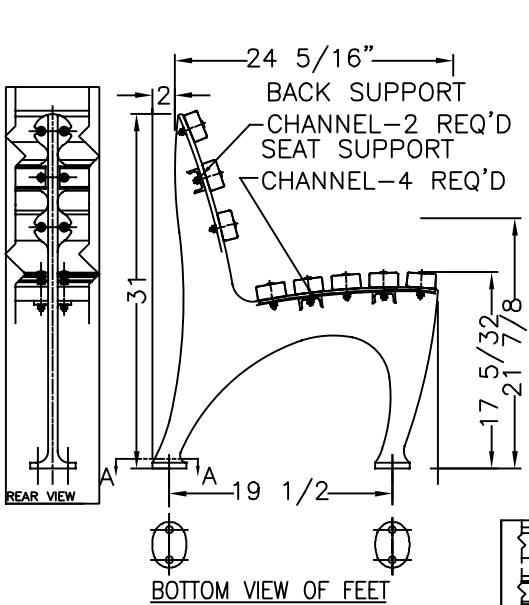
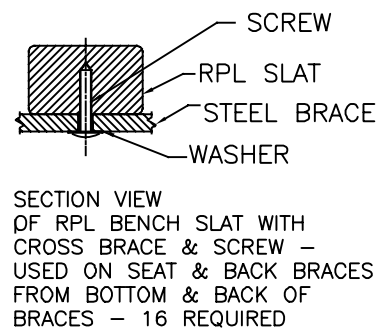
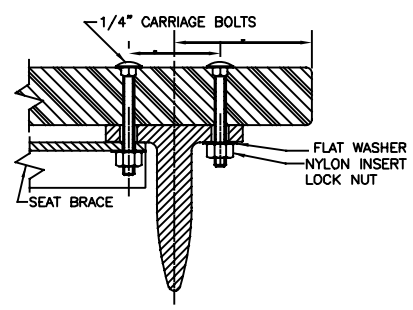
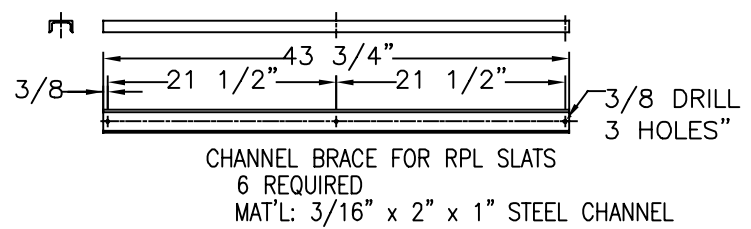
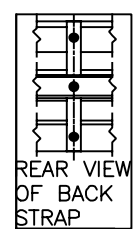

KENNETH LYNCH & SONS
114 WILLENBROCK RD.
OXFORD, CT 06478
PH: 203-264-2831
INFO@KLYNCHANDSONS.COM

6733 1964 WORLDS FAIR BENCH		
Scale FAX	Date 5/13/2024	Drawn T.J.D.
RECYCLED PLASTIC SLATS		8' LONG
3 LEGS	CONTRACT #	
6733-8-RPL-GALV-2024		