

PLAN VIEW

6'-0"

3"

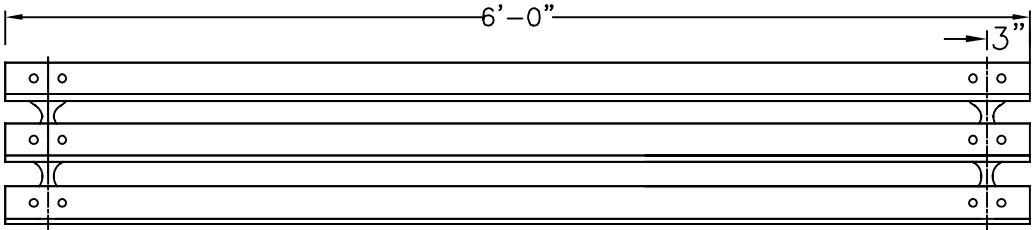

FRONT ELEVATION

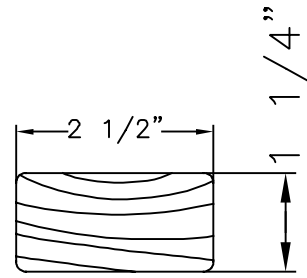
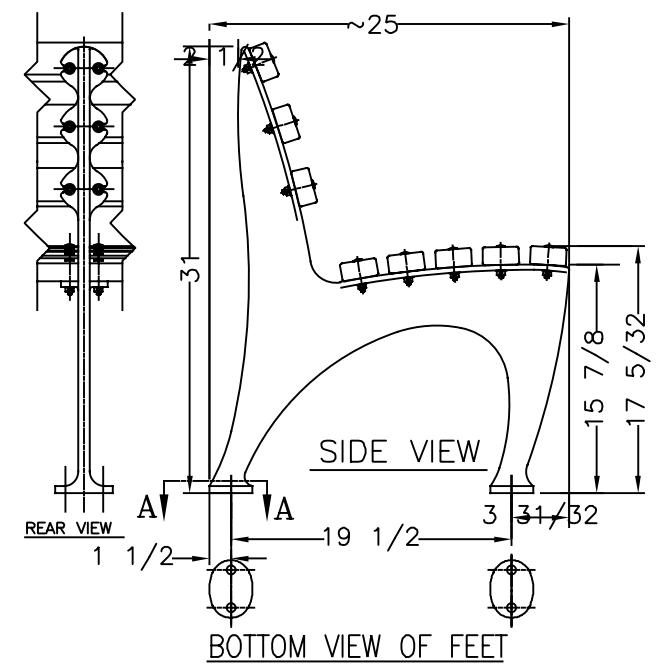

END VIEW OF WOOD SLAT

WHEN USED, ANCHOR BOLTS ARE TO BE INSTALLED IN EACH FOOT OF EACH LEG.

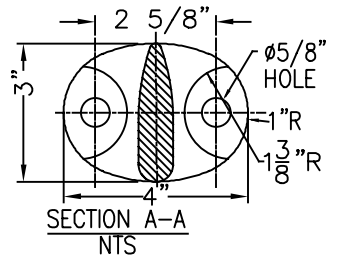
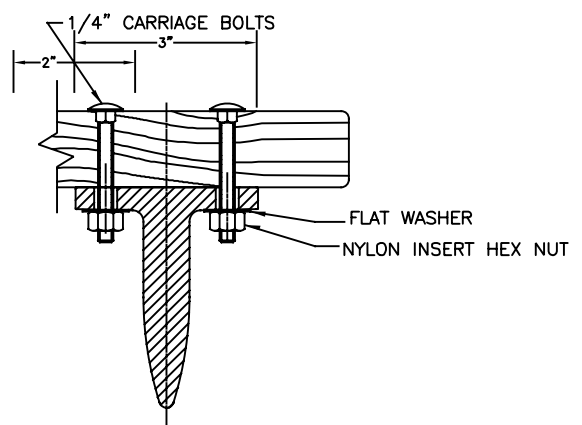

MATERIALS:
 BENCH LEGS: CAST DUCTILE IRON
 WOOD SLATS: CUMARU / DIPTERYX ODORATA
 SMALL FASTENERS (CARRIAGE BOLTS, NUTS, WASHERS & SCREWS): STAINLESS STEEL

KENNETH LYNCH & SONS
 114 WILLENBROCK RD.
 OXFORD, CT 06478
 PH: 203-264-2831
 INFO@KLYNCHANDSONS.COM

6733 1964 WORLDS FAIR BENCH		
Scale FAX	Date 5/13/2024	Drawn T.J.D.
NATURAL CUMARU		6' LONG
2 LEGS	CONTRACT #	
6733-6-CU-2024		