

PLAN VIEW

PIN-IN-TORX TAMPER RESIST SHEET METAL SCREW 18-8 STAINLESS STEEL, BUTTON HEAD, NO 14 SIZE, 1-1/2" LENGTH NOT VISIBLE FROM FRONT OF BENCH

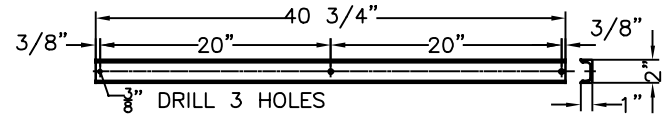

MAT'L: 3/16" x 2" x 1" CHANNEL 2 PIECES

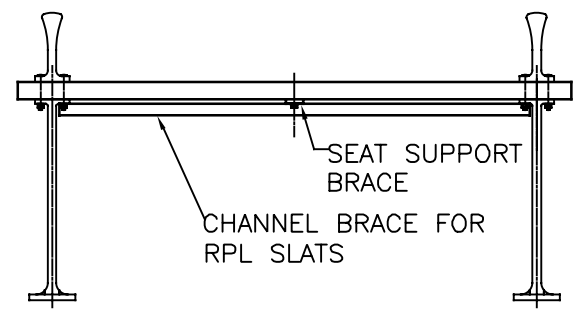

FRONT ELEVATION

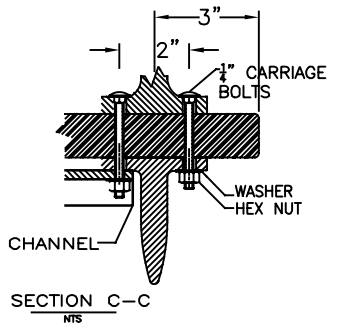

SECTION C-C

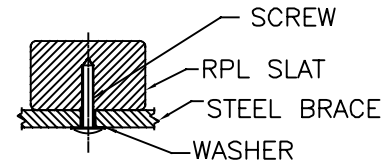

SECTION VIEW OF RPL BENCH SLAT WITH CROSS BRACE & SCREW - USED ON SEAT & BACK BRACES FROM BOTTOM & BACK OF BRACES - 6 REQUIRED

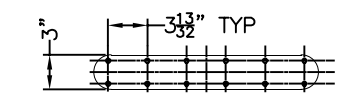

PLAN VIEW OF LEG

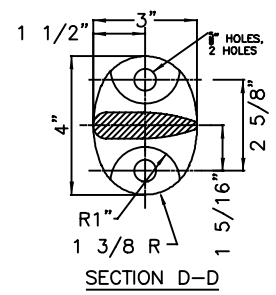

SECTION D-D

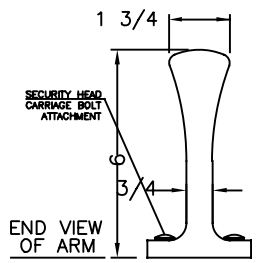

END VIEW OF ARM

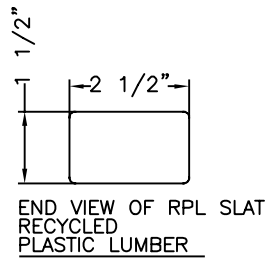

END VIEW OF RPL SLAT RECYCLED PLASTIC LUMBER

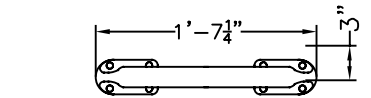

PLAN VIEW OF ARM

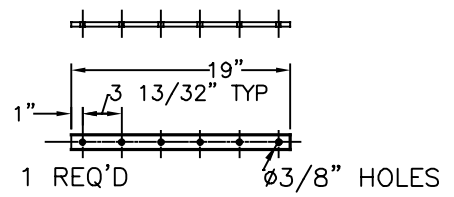

SEAT BRACE FOR RPL SLATS 3/8" x 1 1/4" x 19" HRS

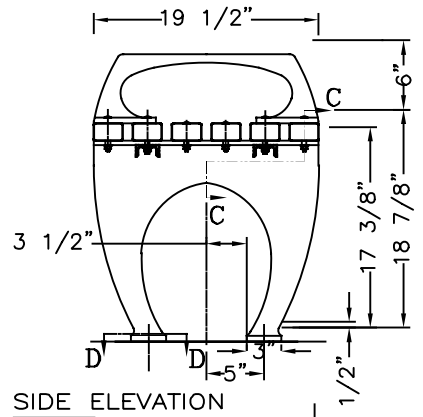

SIDE ELEVATION

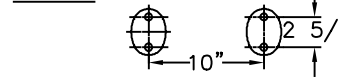

BOTTOM VIEW OF FEET

WHEN USED, ANCHOR BOLTS ARE TO BE INSTALLED IN EACH FOOT OF EACH LEG.

COLOR:
RPL _____
CI & STEEL: GALVANIZED IRON

MATERIALS:
BENCH LEGS & ARMS: GALVANIZED IRON
RPL BRACES: 3/8" X 1 1/4" HRS
3/16" X 1" X 2" STEEL CHANNEL

SLATS: RECYCLED PLASTIC LUMBER (RPL)
SMALL FASTENERS (CARRIAGE BOLTS, NUTS, WASHERS & SCREWS): STAINLESS STEEL

KENNETH LYNCH & SONS
114 WILLENBROCK RD.
OXFORD, CT 06478
PH: 203-264-2831
INFO@KLYNCHANDSONS.COM

6731A 1964 WORLDS FAIR BENCH		
Scale FAX	Date 8/15/22	Drawn T.J.D.
RECYCLED PLASTIC SLATS		4' LONG
2 LEGS	CONTRACT #	
6731A-4-RPL-FX-2022		