

PLAN VIEW

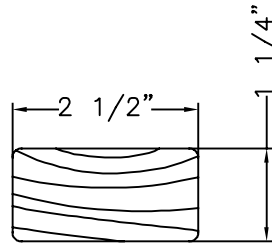

END VIEW OF WOOD SLAT

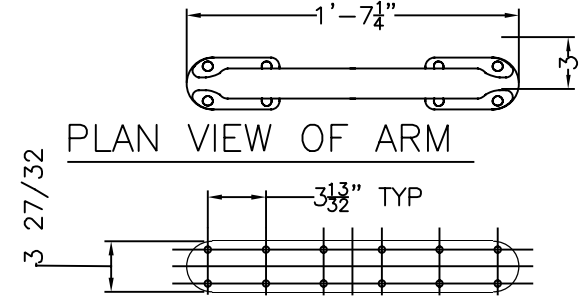

PLAN VIEW OF ARM

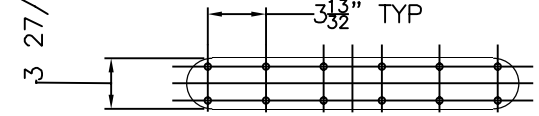

PLAN VIEW OF LEG

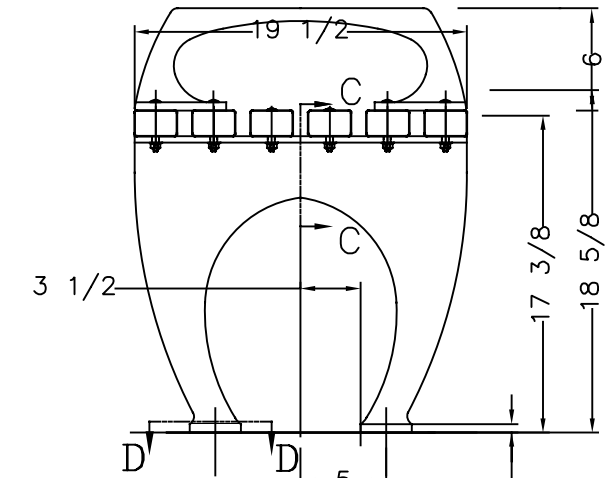
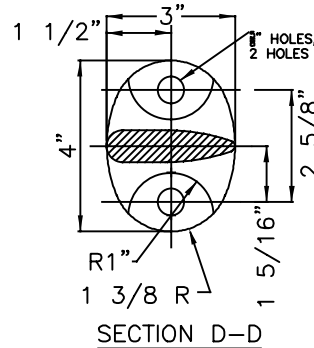
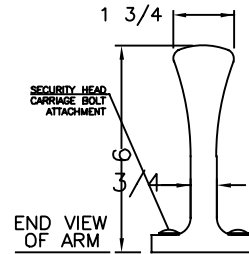
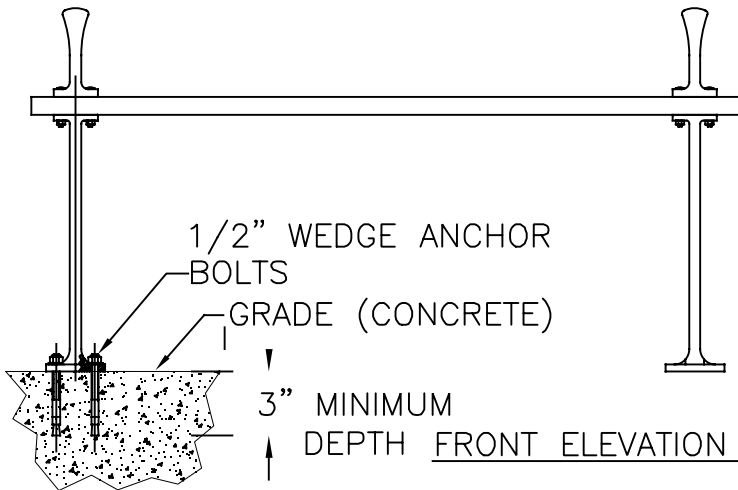

SIDE ELEVATION

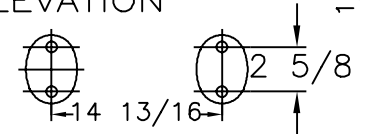

BOTTOM VIEW OF FEET

WHEN USED, ANCHOR BOLTS ARE TO BE INSTALLED IN EACH FOOT OF EACH LEG.

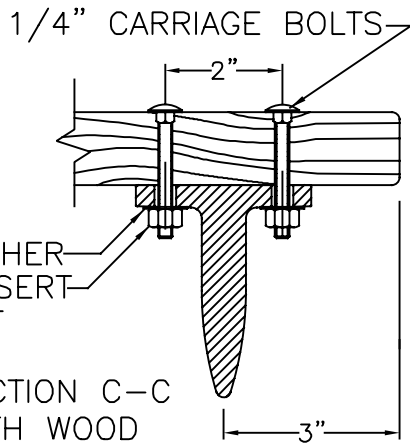

MATERIALS:

BENCH LEGS & ARMS: BLACK STEEL
 SLATS: CUMARU / DIPTERYX ODORATA
 SMALL FASTENERS (CARRIAGE BOLTS, NUTS, WASHERS & SCREWS): STAINLESS STEEL

KENNETH LYNCH & SONS

114 WILLENBROCK RD.
 OXFORD, CT 06478
 PH: 203-264-2831
 INFO@KLYNCHANDSONS.COM

6731A 1964 WORLDS FAIR BENCH		
Scale FAX	Date 5/14/2024	Drawn T.J.D.
NATURAL CUMARU		4' LONG
2 LEGS	CONTRACT #	
6731A-4-CU-2024		