

PLAN VIEW

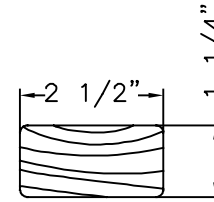

END VIEW OF WOOD SLAT

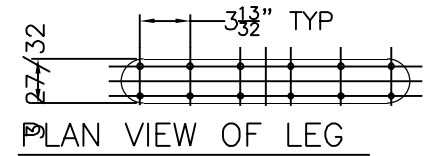

PLAN VIEW OF LEG

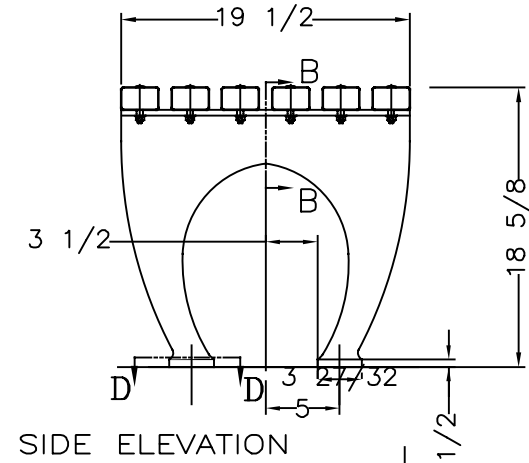

SIDE ELEVATION

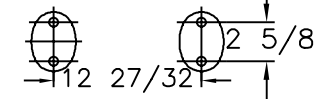

BOTTOM VIEW OF FEET

WHEN USED, ANCHOR BOLTS ARE TO BE INSTALLED IN EACH FOOT OF EACH LEG.

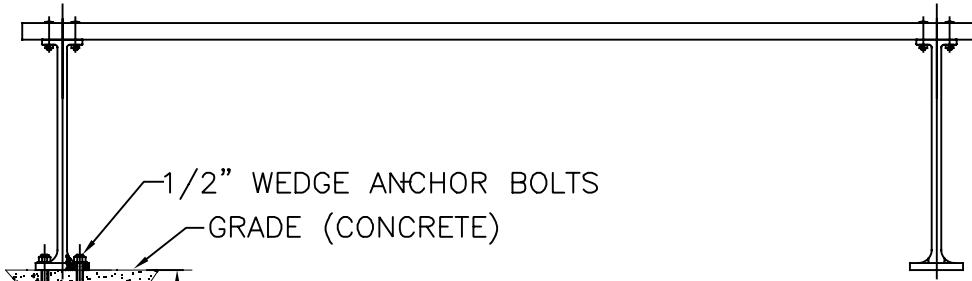

FRONT ELEVATION

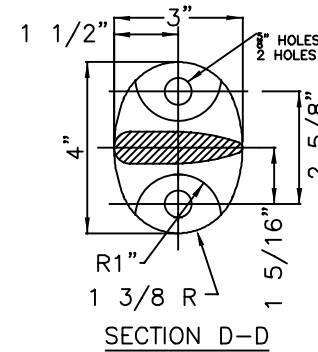

SECTION D-D

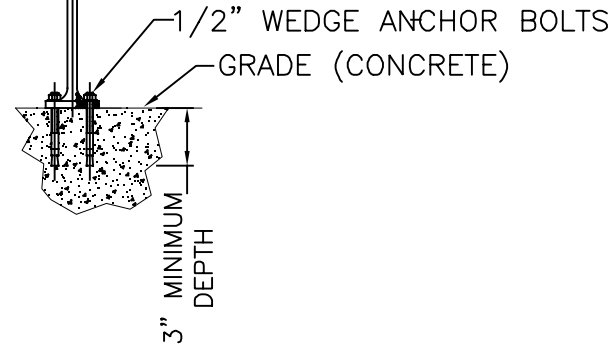

1/4" CARRIAGE BOLTS

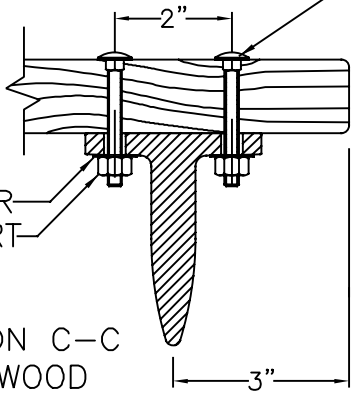

FLAT WASHER
NYLON INSERT
LOCK NUT

SECTION C-C
WITH WOOD

MATERIALS:

BENCH LEGS & ARMS: BLACK STEEL
SLATS: CUMARU / DIPTERYX ODORATA
SMALL FASTENERS (CARRIAGE BOLTS, NUTS, WASHERS & SCREWS): STAINLESS STEEL

KENNETH LYNCH & SONS

114 WILLENBROCK RD.
OXFORD, CT 06478
PH: 203-264-2831
INFO@KLYNCHANDSONS.COM

6731 1964 WORLDS FAIR BENCH		
Scale FAX	Date 5/14/2024	Drawn T.J.D.
NATURAL CUMARU		6' LONG
2 LEGS	CONTRACT #	
6731-6-CU-2024		