



Benches & Garden Seats



Our benches which have wood seats use our standard specified wood which is Ipe (Tabebuia). They are an even brown color when freshly milled and weather to a very nice silvery grey color over time. They are naturally antifungal, very dense and very hard. Vertical Grain Douglas Fir is available on special order. Treatment of the fir by painting or wood preservative is suggested.

1939 NEW YORK WORLD'S FAIR



NO. 6737 NEW YORK WORLD'S FAIR BENCH.

Available in 4', 5', 6' & 8' lengths.

This design was a refinement of an early 20th century bench. Robert Moses and Kenneth Lynch collaborated on the redesign in 1934 and it was then used extensively at the 1939 World's Fair in New York. Unbreakable ductile iron legs, wood slat seat. Can be bolted down. This extremely comfortable bench is in

general use in New York's City Parks as well as on Pier 7 in San Francisco and many other public and private parks and gardens.

**NO. 466 GAME TABLE
(SEE BELOW)**

**NO. 6732 NEW YORK WORLD'S FAIR
GAME TABLE**

32" square.

Companion to the 1939 New York World's Fair bench. Note this sample does not have a checkerboard surface. This is an adaptation of the original design of bench for this World's Fair. Made with fabricated cast ductile iron legs and concrete top with terrazzo playing surface.

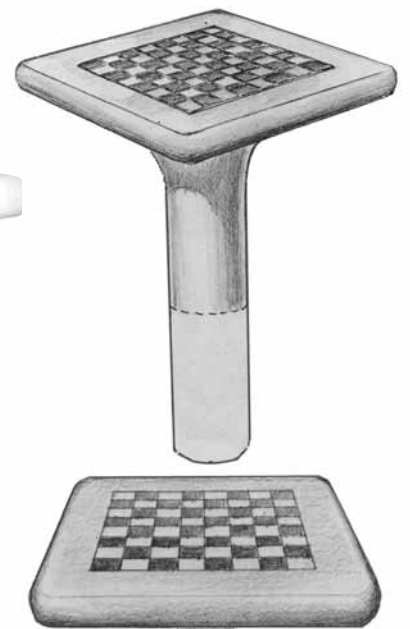

Note: Special bench leg is available.

NO. 466A GAME TABLE

Cast Stone
Well reinforced for permanent installation in concrete.
Top is 2'6" square with terrazzo playing surface. No. 466A has 4" pipe leg. It can also have a 12" square plate welded at the bottom for surface mounting.

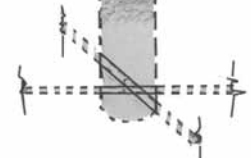



NO. 6737A WORLD'S FAIR BENCH WITH ORNAMENTATION

Available in 4', 5', 6' & 8' lengths.
An adaptation of the World's Fair Bench with decorative ornament applied within the arms and legs. These ornaments change the character of this sturdy old bench to a romantic 20th century design. Unbreakable ductile iron legs, wood slat seat. Can be bolted down.



Note: Arm inserts are available for the original manufacture or refit of benches.



NO. 6734 WORLD'S FAIR PICNIC TABLE.

Modeled after the famous 1939 New York World's Fair Bench. This piece is shown with No. 6738 backless bench. Because this combination did not work well, we are now suggesting that No. 6738 (see pg.416) be used instead. At some point a flat top version of the 6736 may be introduced. 3'w X 7'l x 30"h.

1939 NEW YORK WORLD'S FAIR



NO. 6736 BACKLESS WORLD'S FAIR BENCH

Available in 4', 5', 6' & 8' lengths.

Unbreakable ductile iron legs, with wood slat seat. Can be bolted down. The swale design of the seat proves to be very comfortable. The edges are slightly over height to allow the user to stand up more easily than with a standard flat top backless bench. Now available with arm rests. (See photos below.)



NO. 6736

NO. 6736A BACKLESS WORLD'S FAIR BENCH WITH ARMRESTS"

Backless version of the World's Fair Bench with armrests which discourage sleeping.



NO. 6736A ARMREST FOR BACKLESS BENCH

Iron
Priced per armrest



NO. 6736G DECORATIVE BENCH - GRAPES WITH VINES AND LEAVES



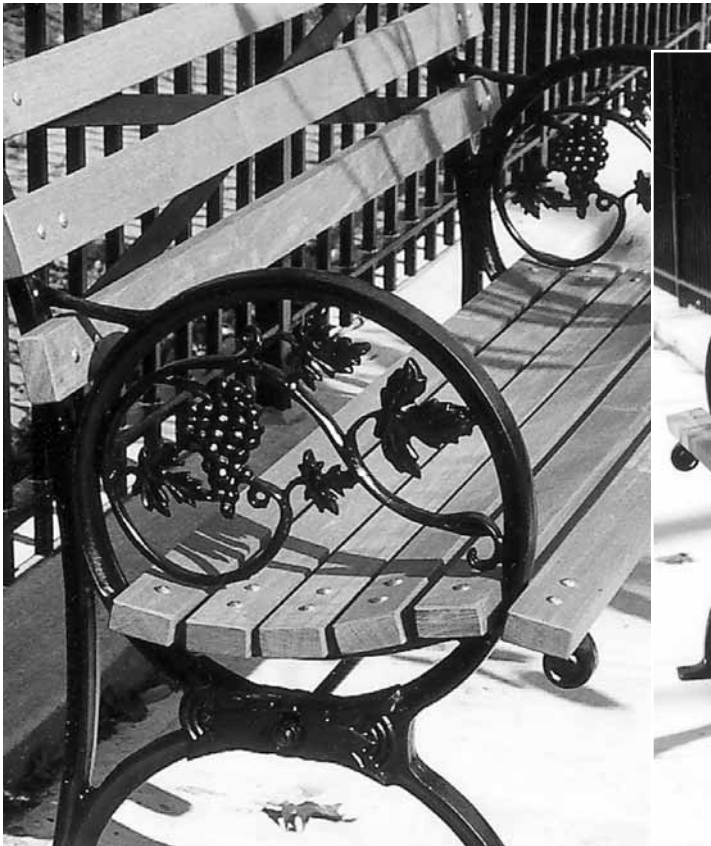

**NO. 6737C 1939 WORLD'S FAIR
ARMLESS BENCH**

Iron
Special application.

**NO. 6737G 1939 WORLD'S FAIR DECORATIVE ORNATE
BENCH**

INCORPORATING GRAPES WITH VINES AND LEAVES
Iron, Available in 4', 5', 6' & 8' lengths.

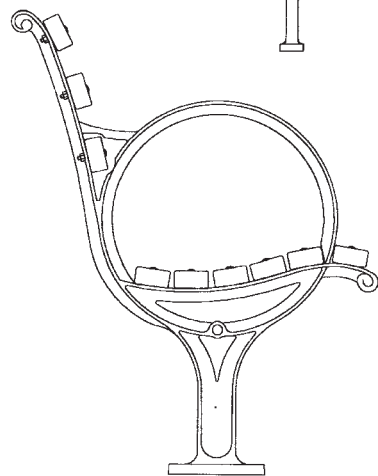
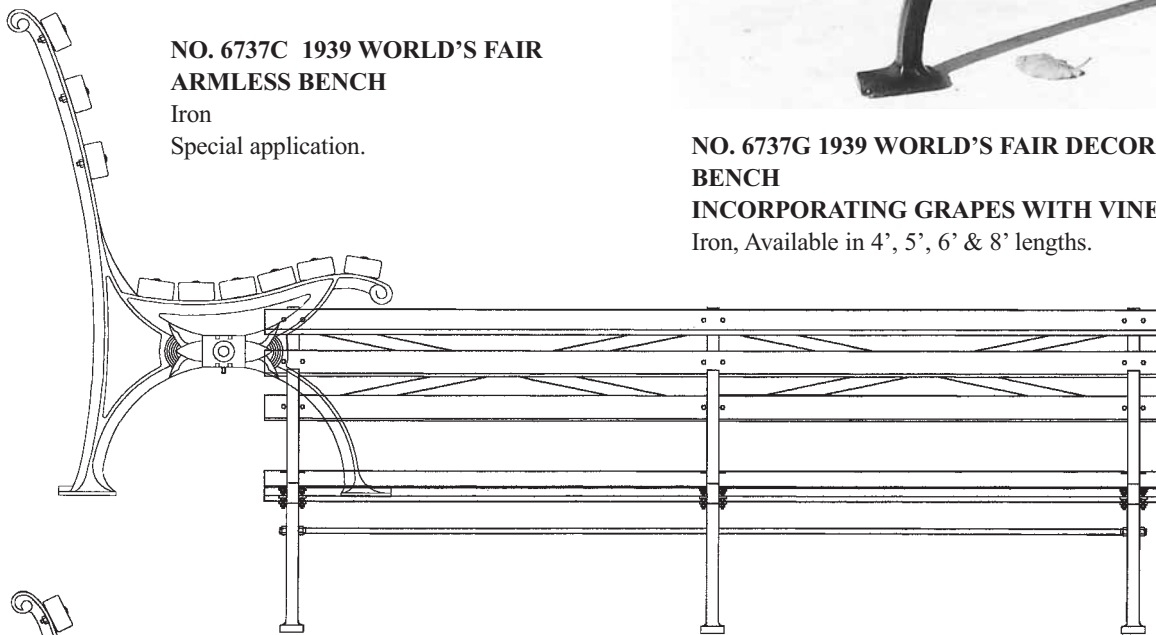

**NO. 6737D 1939 NEW YORK
WORLD'S FAIR SINGLE LEG
BENCH.**

Iron
Available in 4', 5', 6' & 8'
lengths.

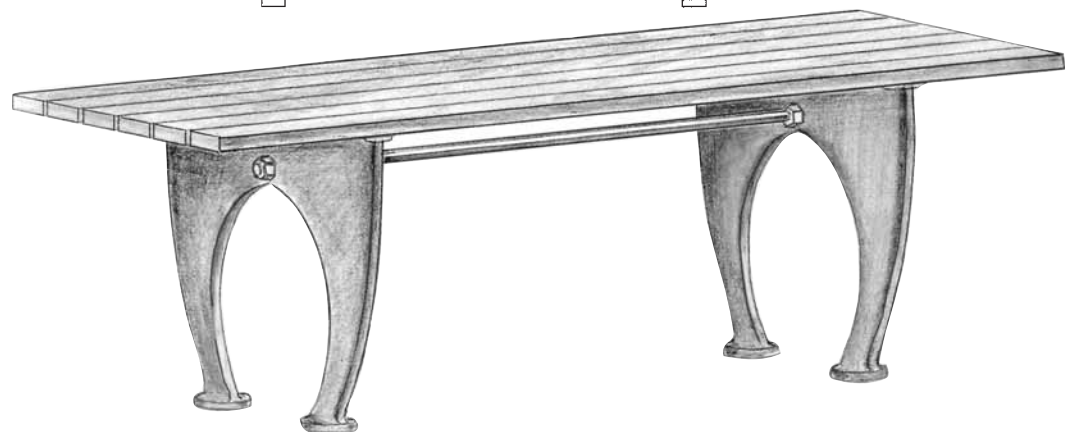

**NO. 6730 1964 WORLD'S FAIR PICNIC TABLE
(ALSO KNOWN AS THE FLUSHING MEADOWS CORONA PARK PICNIC TABLE)**
36" w X 84" l.

This is an adaptation of the original design of bench for this World's Fair. Made with fabricated steel legs and 2 x 6 plank top of IPE wood.

1964 NEW YORK WORLD'S FAIR



NO. 6733 1964 WORLD'S FAIR BENCH

(ALSO KNOWN AS THE FLUSHING MEADOWS CORONA PARK BENCH)

Available in 4', 6' & 8' lengths.

Introduced at the 1964 New York World's Fair. The original had cast aluminum legs and fiberglass channel seat slats. Now manufactured with galvanized ductile iron legs and wood slats.

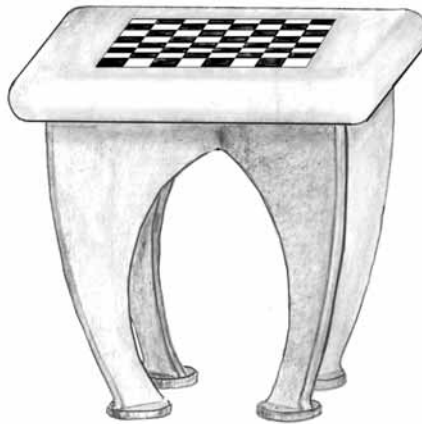

NO. 6730G 1964 WORLD'S FAIR GAME TABLE

(ALSO KNOWN AS THE FLUSHING MEADOWS CORONA PARK GAME TABLE) 32" square.

Companion to the 1964 New York World's Fair bench. Note this sample has a checkerboard surface.

This is an adaptation of the original design of bench for this World's Fair. Made with fabricated steel legs and concrete top with terrazzo playing surface.



NO. 6731 1964 WORLD'S FAIR BACKLESS BENCH

(ALSO KNOWN AS THE FLUSHING MEADOWS CORONA PARK BACKLESS BENCH)

Available in five sizes: 4', 5', 6', 7', & 8' lengths

This is an adaptation of the original design introduced at the 1964 New York World's Fair. Manufactured with galvanized ductile iron legs and wood slats.



NO. 3339 WASHINGTON SQUARE BENCH

Available in 4', 5', 6', and 8' lengths.

Bench is designed for installation where feet bolt below grade level. Unbreakable ductile iron legs. Designed to use 1" x 4" bench slats.

NO. 3339A WASHINGTON SQUARE BENCH (NEW YORK CITY)

Available in 4', 5', 6', and 8' lengths.

Bench is designed for installation where feet bolt on grade level. Unbreakable ductile iron legs. Designed to use regular 1 1/4" x 2 1/2" bench slats.



NO. 3339B BACKLESS WASHINGTON SQUARE BENCH

Available in 4', 5', 6', and 8' lengths.

This backless version is designed for installation where feet bolt on grade level. Unbreakable ductile iron legs. Designed to use 1 1/4" x 2 1/2" bench slats.

NEW YORK BENCHES



NO. 3339C WASHINGTON SQUARE PICNIC TABLE
3'w X 7'l
This picnic table accommodates the 3339B backless bench.



NO. 6740 HERMAN PARK BENCH
Available in 4', 5', 6', and 8' lengths.
Designed by The Olin Partnership for Hermann Park in Houston, Texas.
A rugged, clean and dynamic design. Easy to assemble.



NO. 6739 HOOF BENCH

Available in 4', 5', 6', and 8' lengths.

First introduced in New York City in the mid to late 1800's. This bench has cast iron armrests and feet and uses 3/4" diameter steel bars as legs. There is a unique cast "Hub" joining the parts of the legs together and providing a place for the tie rods to anchor. As shown above, the bench is anchored by a rod that is located in the center of the foot. It fits into a 1 1/4" hole drilled into the pavement below the bench and is secured in place with non-shrink grout. There is an alternate fastening available, so that the bench can be simply bolted down.



NO. 6735 CENTRAL PARK SETTEE

Available in 4', 5', 6', and 8' lengths.

This bench was originally introduced into New York's Central Park in 1858 when the park was first opened. They came into disuse toward the end of the 19th Century and were re-introduced in 1994. Manufactured with unbreakable ductile iron legs, wood slat seats. Can be bolted down. Wood painted Central Park Green or can be left unpainted.

NEW YORK BENCHES

NO. 6738A ARMREST FOR BACKLESS BENCH

Iron
Priced per armrest.

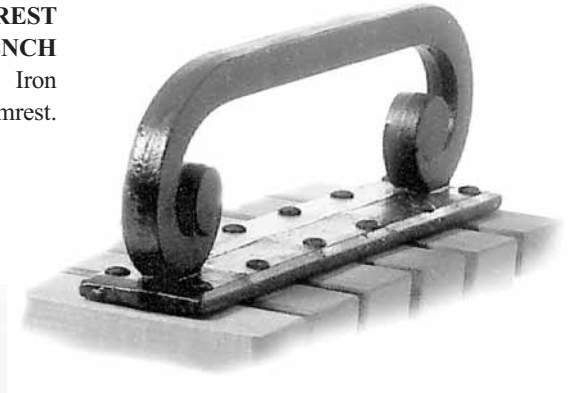

NO. 6738 BACKLESS BENCH WITH UNBREAKABLE DUCTILE IRON LEGS AND WOOD SLATS.

Backless only, available in 4', 5', 6', and 8' lengths.. This bench can be made either with our regular 1 1/4" x 2 1/2" wood slats or with 2" x 6" wood slats. Available with or without arms and can be anchored down. Suitable for public park use. Priced without arms, additional price for arms on a per arm basis. Good companion bench for No.6734 World's Fair Picnic Table.

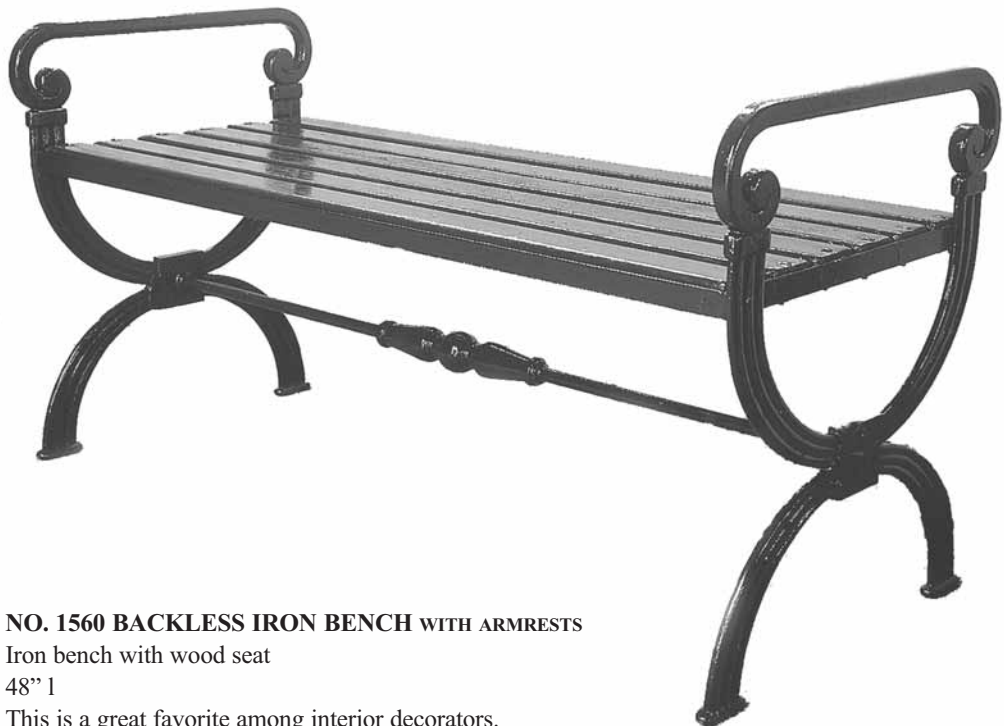

NO. 1560 BACKLESS IRON BENCH WITH ARMRESTS

Iron bench with wood seat
48" l

This is a great favorite among interior decorators.
Unbreakable ductile iron legs.

Note: now made without ornament at center of the tie rod.



NO. 1162 BENCH WITH BACKREST

Cast Stone

54"l X 35"h X 17"w (total)

Seat, back, and arms are made as one piece. Legs are separate and can be attached to bottom of seat with threaded rod.



NO. 907 BAROQUE BENCH

Cast Stone

18 1/2"h X 48"l X 19"w at widest point.



NO. 1304 ORNAMENTAL BENCH

Cast Stone

47"l X 17"h X 12 1/2"w

Highly ornamental design and very strong because it is built up in the center like a beam, with scrolls under the top slab.



NO. 1762 MOROCCAN BENCH

Cast Stone

6'l X 18"w X 17"h

This bench is very heavy. Its weight is approximately 900 lbs.

STONE BENCHES

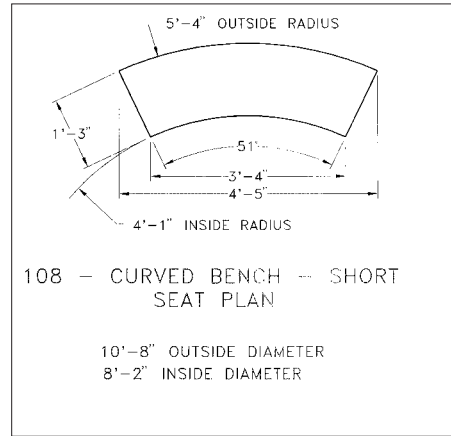

NO. 108 CURVED BENCH

Cast Stone

Available in two sizes: Bench is 4'5"l & 5'1 1/2"l, Curved

Note the T-shaped Irish safety legs. It will not topple. See drawings for details.

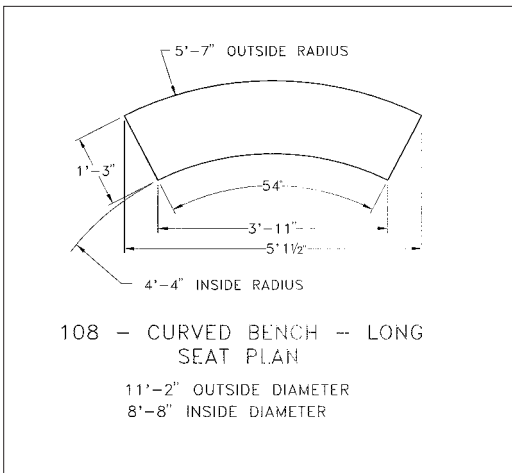

NO. 108 STRAIGHT BENCH

Cast Stone

Available in two sizes:

Bench is 4'l & 5'1 1/2"l.

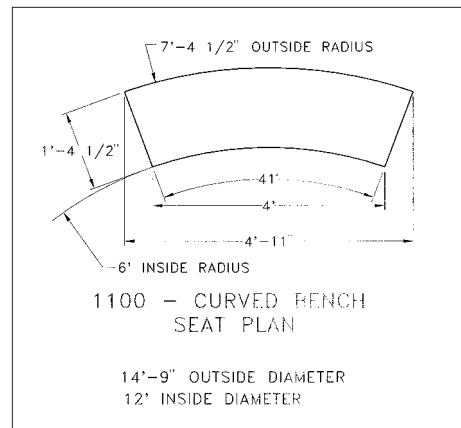
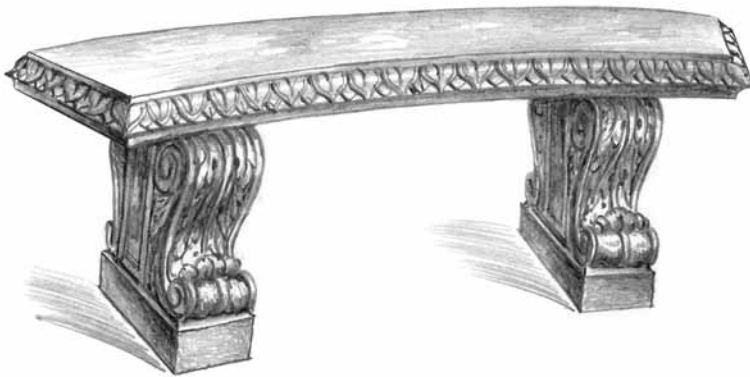

NO. 1100 CURVED BENCH

Cast Stone, 4'11"l

Bench curved and highly ornamental.

Please note: Benches No. 1100 and No.1101 can use either leg style for the curved or straight top.



NO. 1101 STRAIGHT BENCH

Cast Stone, 60"l

Bench is furnished straight only.

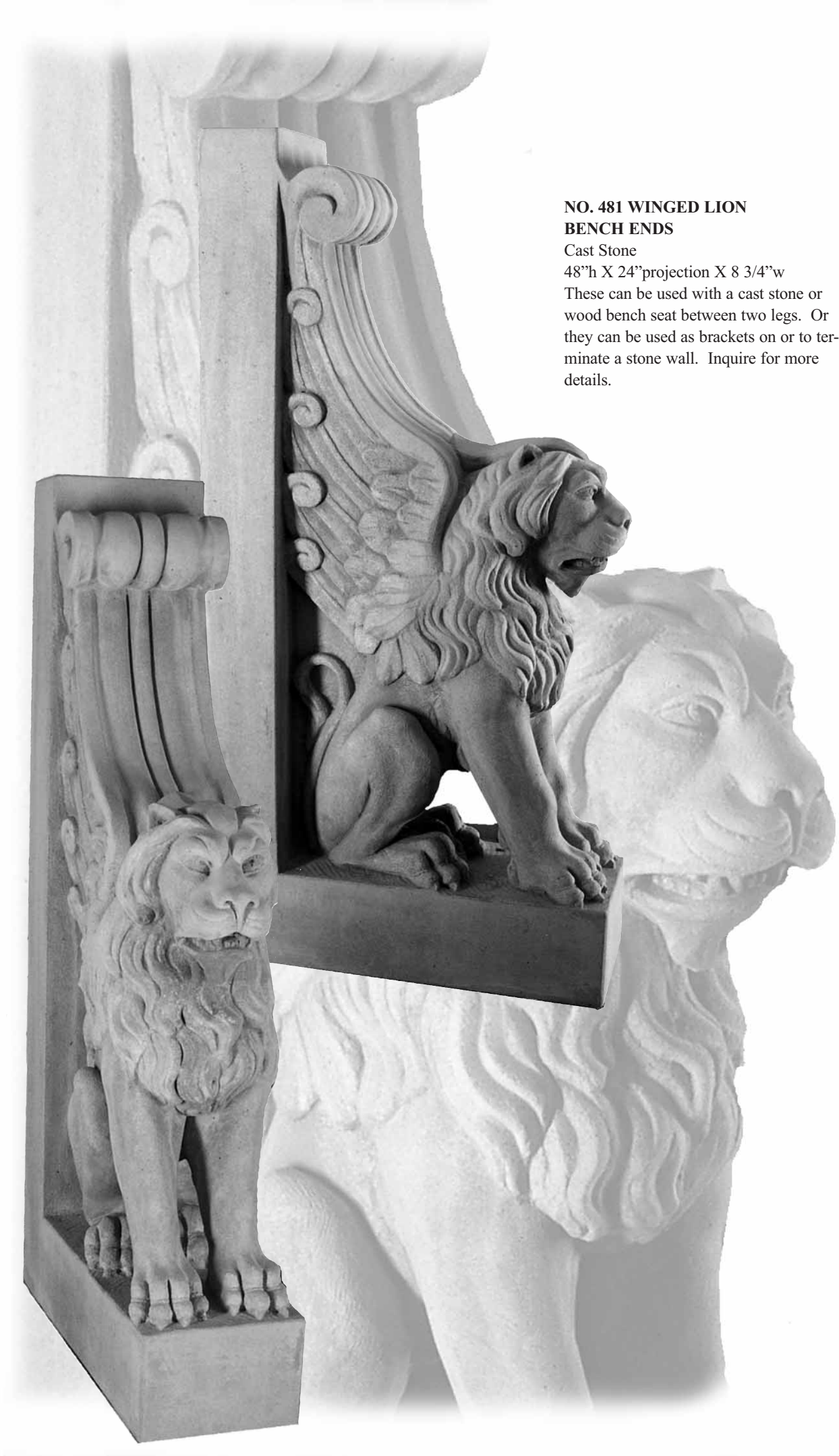

**NO. 481 WINGED LION
BENCH ENDS**

Cast Stone

48" h X 24" projection X 8 3/4" w

These can be used with a cast stone or wood bench seat between two legs. Or they can be used as brackets on or to terminate a stone wall. Inquire for more details.

STONE BENCHES

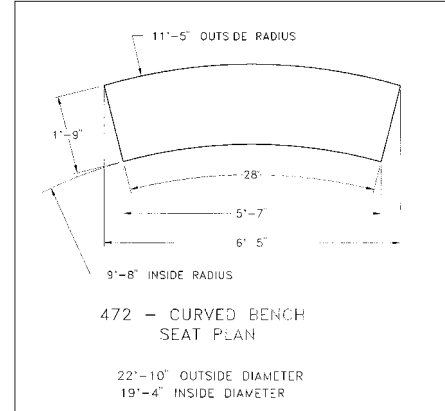

NO. 472 LIBRARY BENCH

Cast Stone
6' 5"l X 21"w X 18"h. Leg 12"w.
Also available curved (shown).
9'8" inside radius, 74"l X 18"w.



NO. 472A LIBRARY BENCH

Cast Stone
With more delicate legs: 7"w.
Same dimensions as No. 472.



NO. 480 STRAIGHT BENCH

Cast Stone
This extremely sturdy bench is offered
in 4', 5', or 6' lengths.

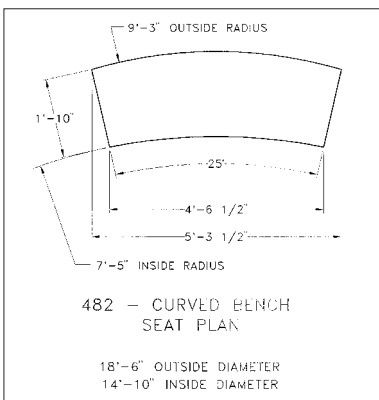

NO. 482 CAST STONE BENCH

Cast Stone
Available in 4', 5' & 6' lengths.
This bench has extra strong detail and would look attractive
in any garden. The top is specially reinforced. Also furnished
curved. See drawing for details and dimensions.

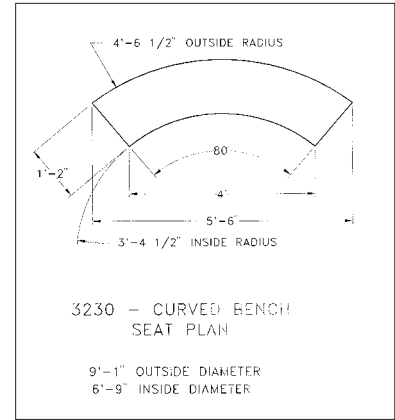
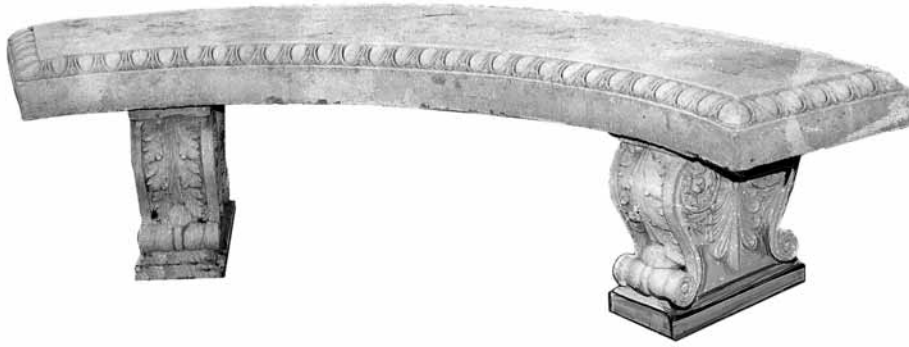

NO. 3230 EGG & DART BENCH

Cast Stone
66"l X 18"h. 40" inside radius. 4" thick top.
Curved Bench with Egg & Dart Molding.

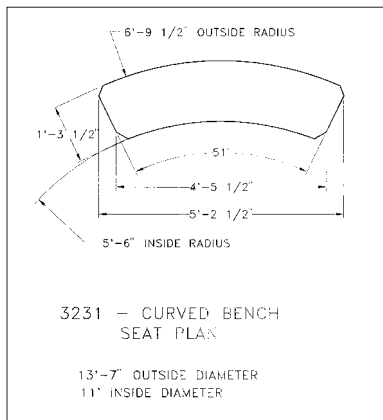

NO. 3231 RELIEVED CORNER BENCH

Cast Stone.
66" inside radius, 62"l X 15 1/2"w
Curved Bench with relieved corners.



NO. 470 STRAIGHT BENCH

Cast Stone, 3' x 8'
Designed for seating from both sides,
or can be made any reasonable size to suit.



NO. 936 STRAIGHT BENCH

Cast Stone
Available in three sizes: 4', 5', & 6' long. Straight only.

BENCHES & TABLES



NO. 474 BENCH

Cast Stone

Very rugged bench reinforced with steel and made in 4' units only. They look very well in groups.

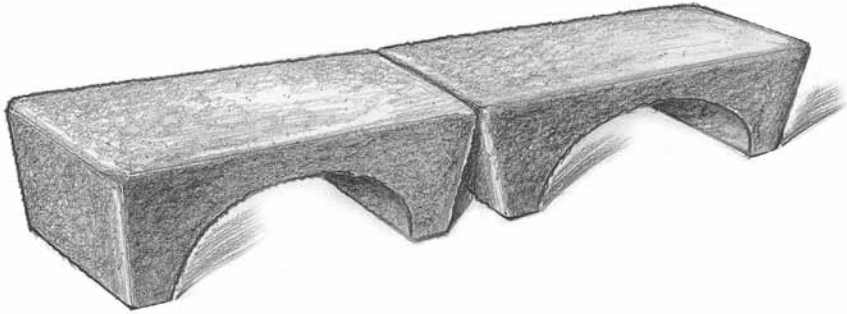

NO. 782 COCKTAIL TABLE

Cast Stone

16"h X 15"w X 15"diameter

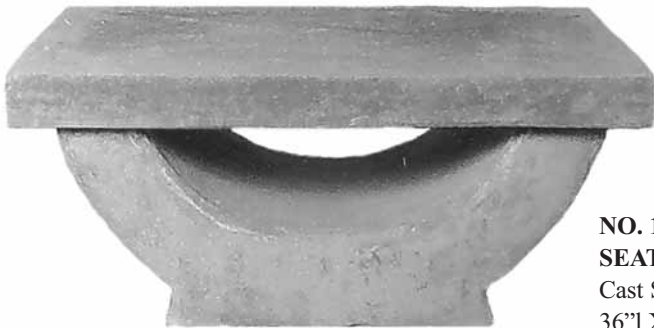

NO. 1285 JAPANESE GARDEN SEAT

Cast Stone

36"l X 18"w X 16"h.

Garden seat of Japanese design.

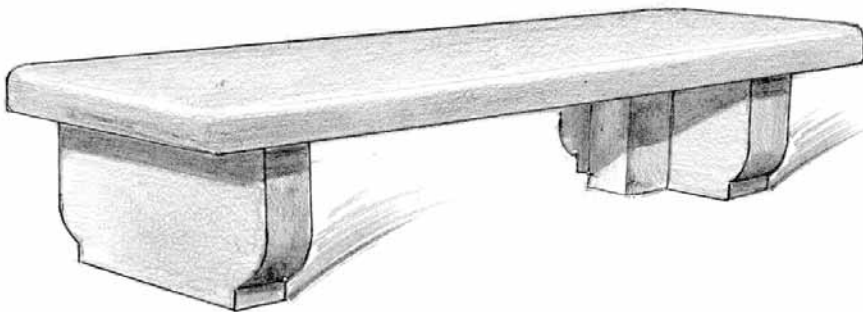

NO. 4861 STRAIGHT BENCH

Cast Stone

16"h X 20"w X 6'l

Note the Irish safety legs.

NO. 1141 PINEAPPLE TABLE

Cast Stone, 32"h

Top 30" diameter

Bottom 15" diameter

The table top and lamb's tongue edge are sanded to expose the limestone aggregate that we use in our Cast Stone products. See No. 1774 Leaf Pedestal as an alternative base for this table top. Although the base is shorter, an adaptor can be placed underneath to raise it to the correct height.

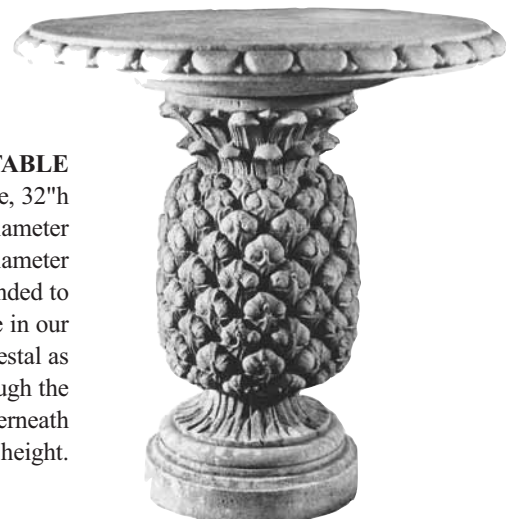



NO. 146 GARDEN SEAT FIGURE
Cast Stone, 16" h



NO. 1145 ELEPHANT GARDEN SEAT FACING LEFT
Cast Stone, 20" h
Base 10" X 14"

NO. 584 HASOCK GARDEN SEAT

Cast Stone
14 1/4" w X 13 3/4" h
Imitates a bamboo likeness.



NO. 1301 GARDEN SEAT
Cast Stone
22" h X 26" w, 17" front to back.

NO. 4697 PILLOW SEAT
Cast Stone
16" w X 21" l x 14" h



WROUGHT IRON BENCHES

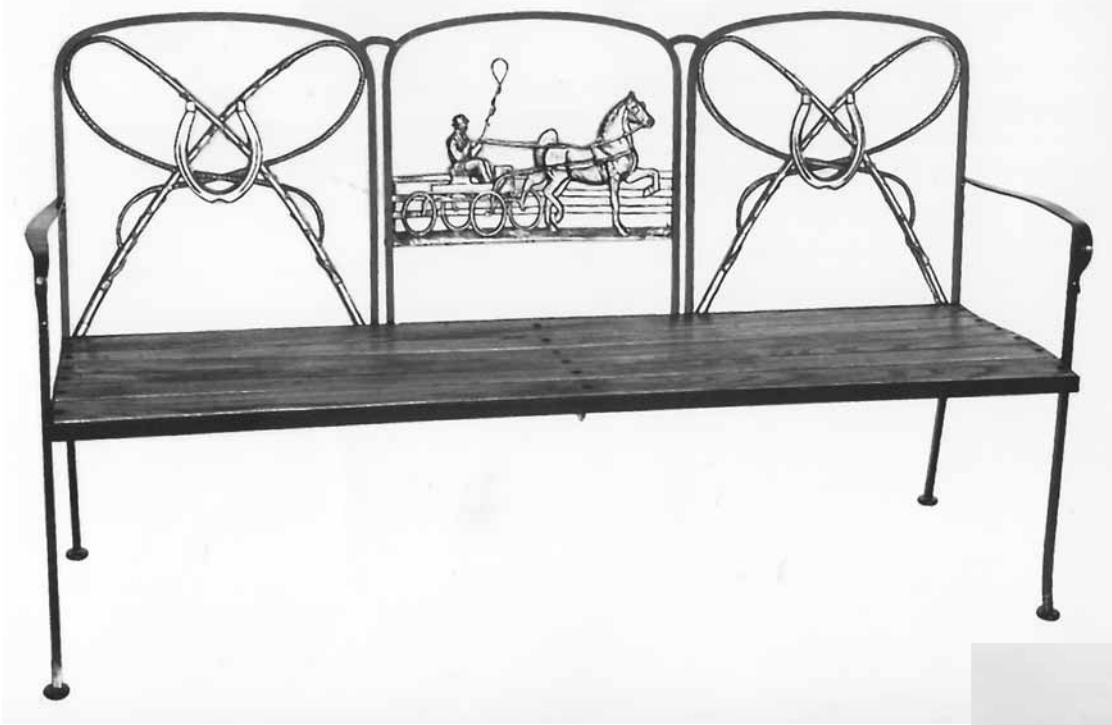

NO. 3783A HARNESS DRIVING BENCH

Wrought Iron, 60"l

Wrought iron bench with all brass decoration.
Very beautifully modeled, with wood seats.

NO. 3795 BRASS HORSESHOE & WHIP BENCH

Wrought Iron

20" wide at seat, 22" overall.

Wrought iron arm chair, brass horseshoe and
whip, made of generous proportions.



NO. 3783 FOX HUNT BENCH

Wrought Iron/Brass, 60"l

This extremely ornate wrought iron and brass bench designed by Mr. Teddy Tiffin about 1910. Wood seat, brass parts polished and lacquered, iron is painted black or Central Park green. This is a most desirable and beautiful bench.

NOTE:

These wrought iron and brass furniture pieces are entirely hand-made and are made to order only. Usually the delivery time is 90 days, so the customer must be patient. They are nicely made and have an elegant look.

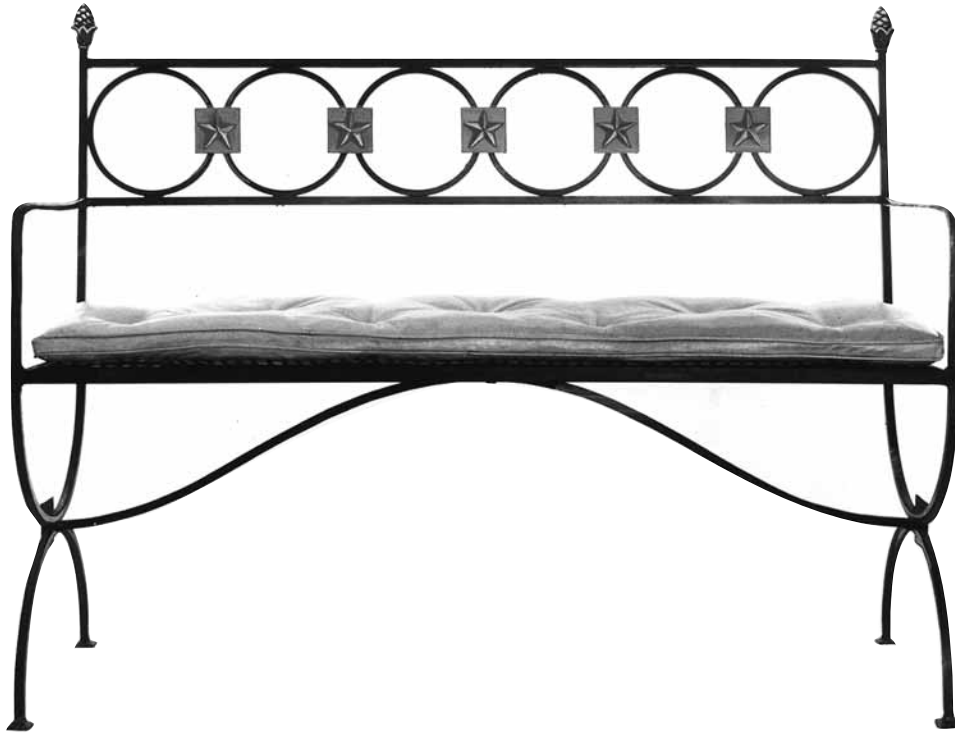

NO. 1557 IRON BENCH

Wrought Iron, 48"l

Decorated with Bronze pinecones and stars.

Bench generally painted Central Park green, white or black.

We do not furnish cushions.



NO. 2724 IRON BENCH

Wrought Iron

Available in 4', 5' and 6' lengths.

Painted white, black or Central Park green.

A truly handsome hand wrought iron bench.

WROUGHT IRON BENCHES

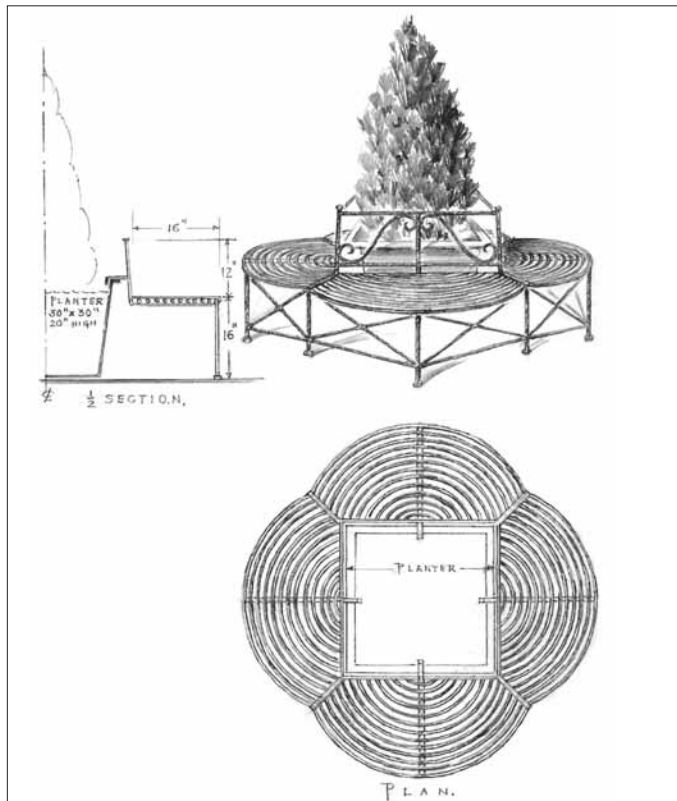

NO. 3359 ROUND THE TREE BENCH

Wrought iron round-the-planter bench with what appears to be individual seats. The planter is 30" x 30" square x 20" high and is arranged to be permanently installed. The planter itself supports the back of the bench. The overall diameter is 62". It is made entirely of unbreakable wrought iron. It is finished in either Central Park green, black or white.

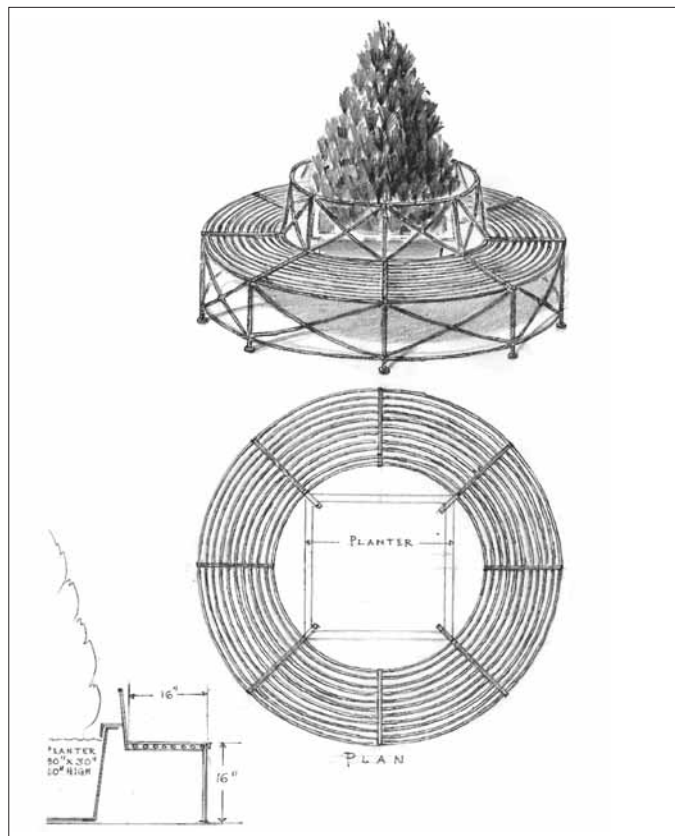

NO. 3360 ROUND THE TREE BENCH

Circular round-the-planter bench is 62" in diameter. The planter is installed permanently in the center of the bench and the back of the bench rests on the corners of the planter. The overall diameter is 62" and it is made completely of wrought iron. It is finished in either Central Park green, black or white.

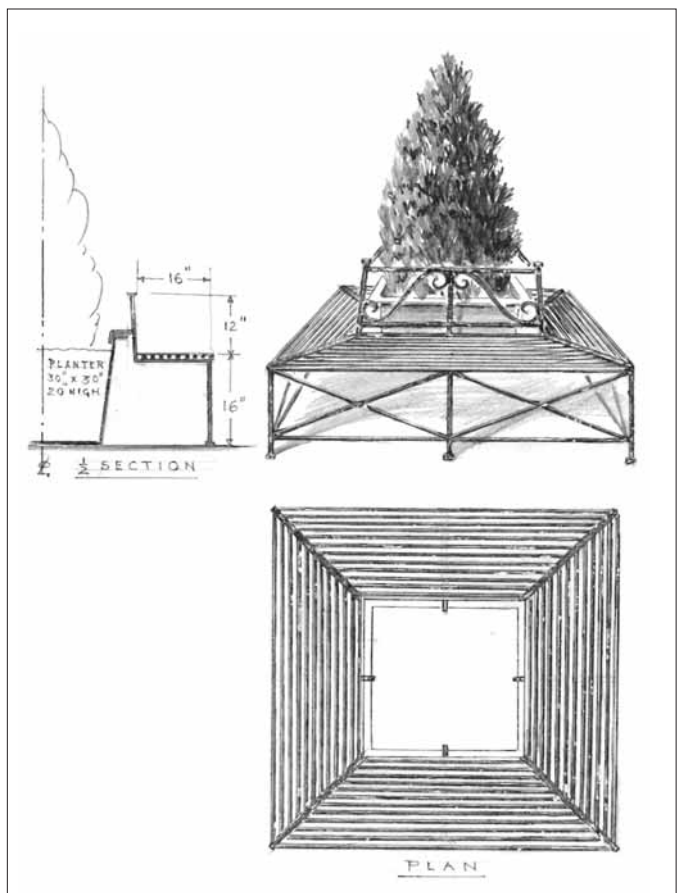

NO. 3361 ROUND THE TREE BENCH

Square round-the-planter bench with a planter perfectly installed in the center. The planter acts as the back support. Furnished in either Central Park green, black or white. It is 5' - 2" square.

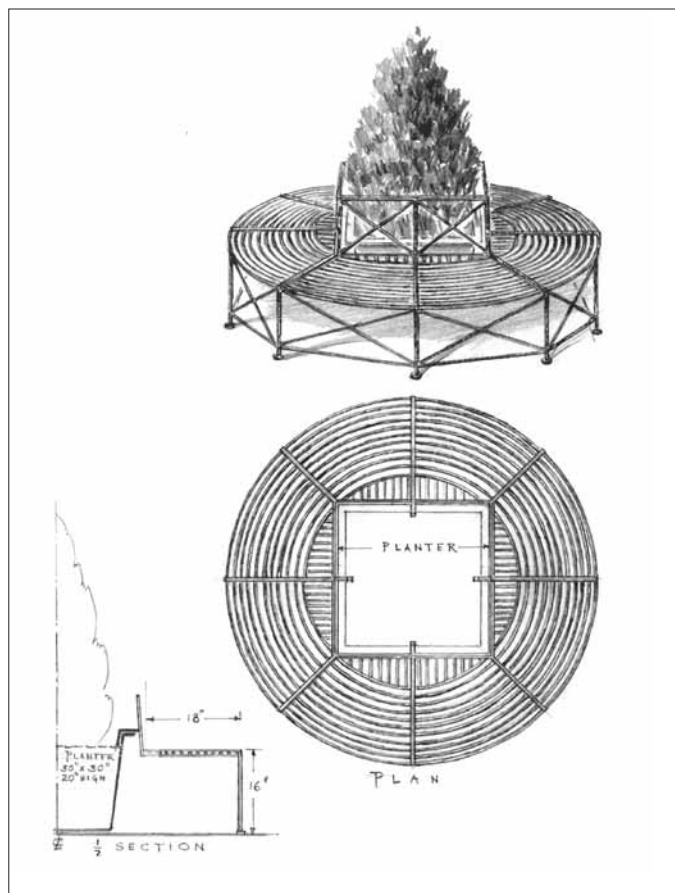

NO. 3362 ROUND THE TREE BENCH

Wrought iron round-the-planter bench furnished in either Central Park green, black or white. The planter acts as a support for the bench. The under-rail can be redesigned for the convenience of cleaning. The overall diameter is 5' to 6' or as necessary for the size of the tree.

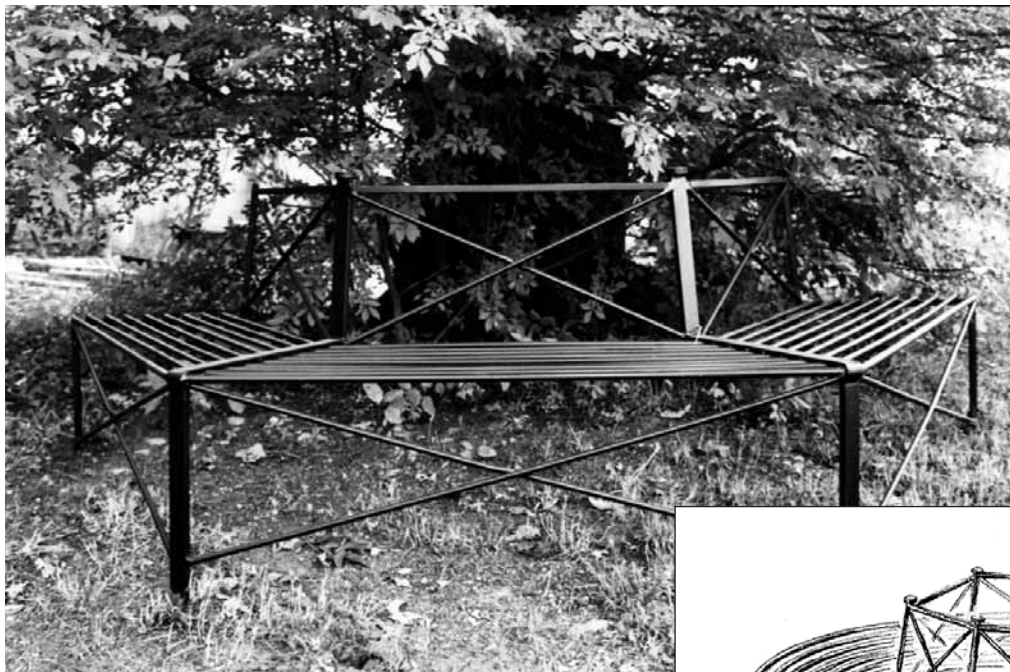

NO. 3233 ROUND THE TREE BENCH

Diameter overall 5'.

Wrought iron bench made in sections to go around trees. This classic design of the back and leg stretchers are much desired.

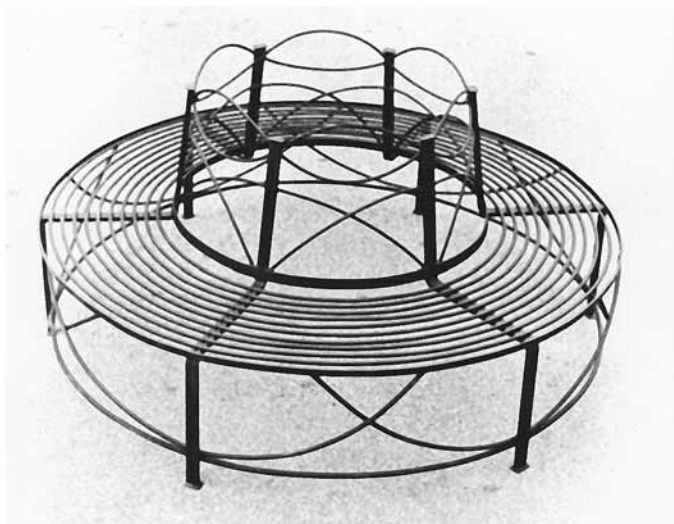
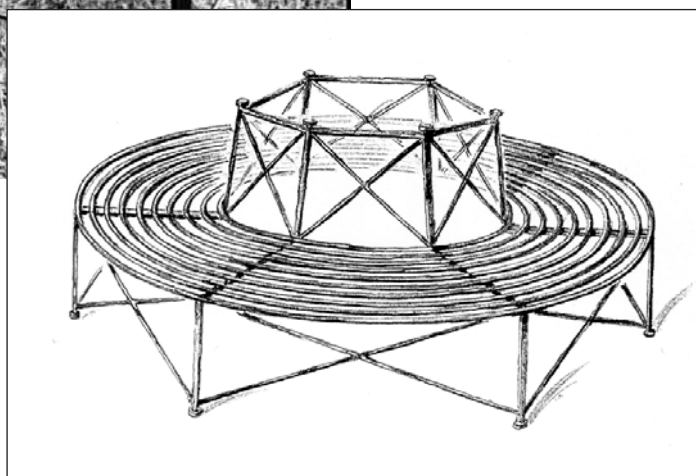

NO. 2725 ROUND THE TREE BENCH

Furnished in all diameters up to and including 12'.

Wrought iron bench to go around a tree. The seat part is 17" front to back. The seat and back are made of round iron. Generally, the opening for the tree is not less than 2', so a minimum bench would be 5' in diameter.

NOTE: All wrought iron benches are custom made. Therefore, the specifics of lengths radius, etc., can be modified or changed to fit the particulars of the job.

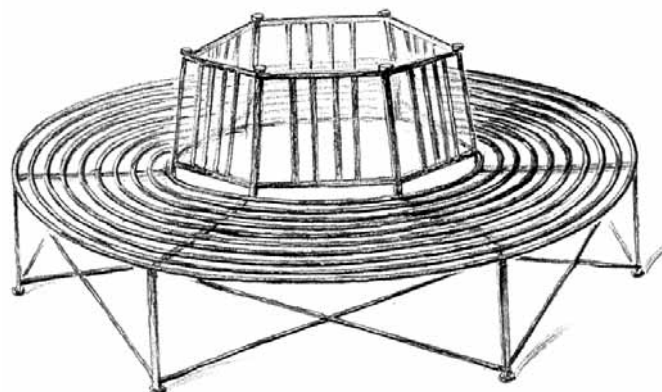

NO 3261 ROUND THE TREE BENCH

Diameters up to 12'.

Wrought iron bench of classic design. It is made of round iron. Note that this design is made in segments to fit together. This is the least expensive of "round-the-tree benches of large dimensions. It is 5' diameter overall and, of course, can be made larger.

BENCHES



