

# Weathervanes

## THE ROMANTIC HISTORY OF WEATHERVANES AND THEIR USE

The weathervane being basically comprised of a sail or flat area for wind to blow against, and an arrow to point into the wind, afforded an opportunity for artistic expression of every conceivable kind. Everything has been cut out of these sails, including initials, dates, hearts, horseshoes, heraldic devices, sometimes even just a pattern of holes. Likewise, the sail was decorated with a fancy border in the form of fleur-de-lis or balls, and then there seemed to be tails added to counterweight an overly heavy arrow.

Who generally made weathervanes? This is an excellent question and it seems that weathervanes most generally were made either by blacksmiths or sheet-metal workers, and in the latter part of the 19th century metal spinners began to play an important role in the making of weathervanes. There were many firms specializing only in parts for weathervanes such as the spun balls, spun terminals and ornaments such as fish, roosters, arrows, etc. These parts were furnished in either zinc or copper and were

spun or stamped was left to the who was general sheet-metal or blacksmith to these pieces and them into weath-



## INTRODUCTION TO WEATHERVANES AND THEIR SPECIFICATIONS

A weathervane is not only a piece of architectural furniture but it is also an instrument to tell the direction of the wind. Mounted as high as possible, it is generally installed on a spire or a cupola. Many times a lightning ground wire is attached to the main shaft.

Kenneth Lynch & Sons has been making weathervanes now for more than fifty years. Experience has taught us that a weathervane should be from 2" to 3" in length for each foot of elevation of a one-story building. This depends largely on the location of the building for certainly a one-story building situated on a high hill and having no cupola on it might require a larger weathervane than that same building on the same high hill with a cupola on it where the weathervane stands out in greater silhouette.

A weathervane on a church steeple or on the top of a tall building is another matter entirely and there is no general rule that can be applied. However, the recommendation about drawing the weathervane to scale on the building elevation is very important.



The two things about almost any building which attract immediate attention are the entrance and the roofline. A suitable weathervane enhances and dramatizes those important areas.

The weathervane is likely to be the only moving thing on the building. It tells a story of what is happening at that moment - which way the wind is blowing and also how the building itself is oriented, since you immediately see the cardinal points of the compass.

While most weathervane art in America is typically American, everything has been used from the famous American trotting horse to Indians, and other things of local interest. Likewise with many weathervanes brought here from Europe the influence of European weathervanes, particularly bannerets and monogram vanes, was certainly felt in American architecture. Weathervanes reflected the character and identity of the people who bought them, their trades, their hobbies, their sports, and in many cases their zodiac symbols. For sure a weathervane was put at a point where all could see and admire it, and, of course, enjoy it.

The use of wrought scrolls and balls does a great deal for a weathervane. Two of the best examples of this treatment are the Old North Church in Boston and the Wren Building at William and Mary College at Williamsburg. Both of these spires are generously decorated with wrought scrolls, balls and other treatment. This gets the weathervane up in the air where it belongs and gives it a very decorative connection with the building proper.

For the weathervane itself we use copper, aluminum or stainless steel paying attention, and guarding against as much as possible, the possibility of metal fatigue. The weathervane must be balanced, that is the sail must be counter-balanced by the opposite end of the weathervane in order to make it turn in lively enough fashion. The bearing system is as simple as using only one single ball for the weathervane to rotate on. Nothing more complicated must ever be used for a weathervane, once installed, is difficult to get to for adjustments. Always use a painted stainless steel shaft. The taller the weathervane the heavier the shaft must be as there is a great tendency for it to bend at the point where it penetrates the roof. All shafts must go through the roof and be fastened to a collar beam or some other such cross member underneath. On grand scale weathervanes we have used solid steel shafts as big as 3" in diameter. However, for the average weathervane, a shaft 3/4" to 1" in diameter is sufficient, but depending upon the "sail area" the weathervane maker will select a shaft that will do the job, for it must not bend. Needless to say, the weathervane shaft must be absolutely vertical. Otherwise the vane will tend to "lay" in one position. Generally three finishes are offered on weathervanes - gold leaf, acid patina (same as for bronze statuary on bronze and copper only) and paint on aluminum and stainless steel. Leaving a copper weathervane to "age" naturally is an option as well.

All of the foregoing should be shown on a simple shop drawing so that the design fits the condition and that all of the problems are solved, including the proper anchoring, etc.

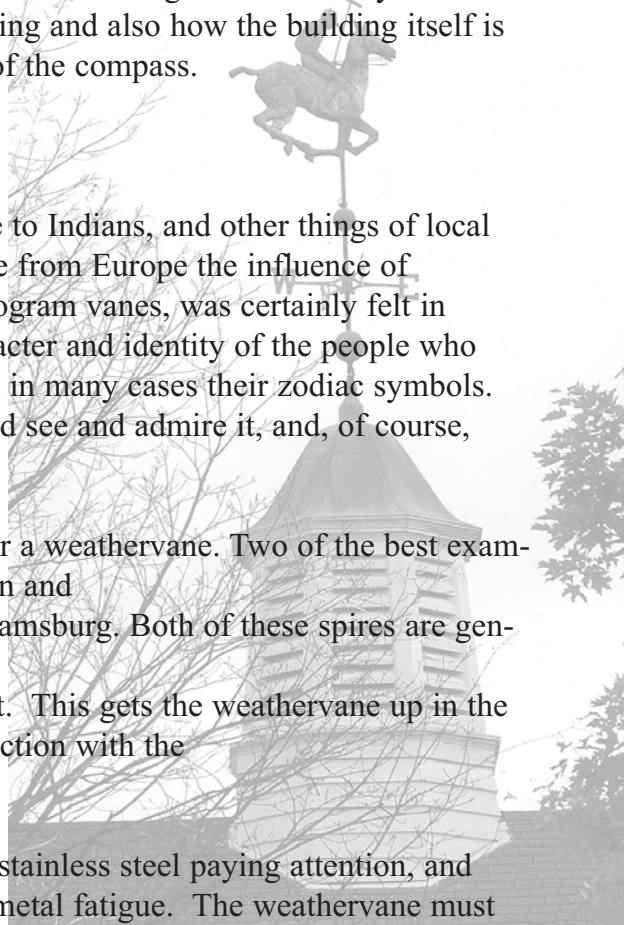

## OLD NORTH CHURCH

**K**enneth Lynch & Sons has made thousands of weathervanes for now famous buildings, but our restoration of the weathervane on the Old North Church is by far of greatest interest seconded only by the repair of the bannerette weathervane on the Old South Meeting House in Boston in 1982.

On August 31st, 1954, the steeple of the Old North Church in Boston was blown from its ancient moorings by one of the fiercest hurricanes that the East Coast had ever experienced to that time.

Although the steeple that fell was not the original one in which Robert Newman hung his "Lanthorns" in 1775 (that structure was blown down in 1884), one significant part of the first steeple remained: the banner shaped weathervane formed under the master hammers of Deacon Shem Drowne before the Union was born. Kenneth Lynch & Sons restored, regilded and assisted in reinstalling this historic weathervane.

We are very proud to be associated with this historic work. Paul Revere, who read the signal, "One if by land or two if by sea" from Mr. Newman's "lanthorn", was also a metal worker.

Photograph taken by passer-by at the crucial moment during August 1954 hurricane as Old North Church steeple begins to fall.

Using its old banner shaped weathervane, damaged but recognizable, as a symbol, an appeal was made to Americans everywhere throughout the land. The response was not long in coming. Donations in cash, materials and services, from school children, private individuals, associations, clubs, and many large businesses across the country, poured into Boston on a flood of characteristic generosity and patriotism. ■

*This special Vane of the Old North Church, in Boston, MA, was refurbished and regilded by Kenneth Lynch & Sons for the Bicentennial Celebration in 1976.*

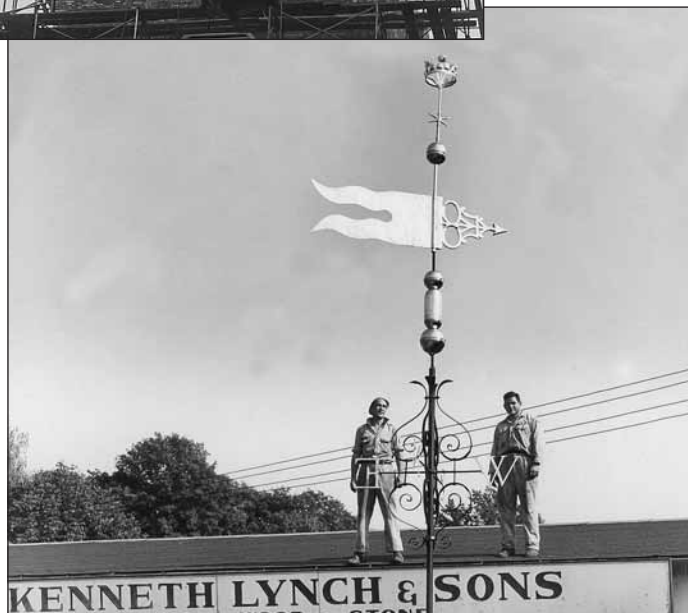

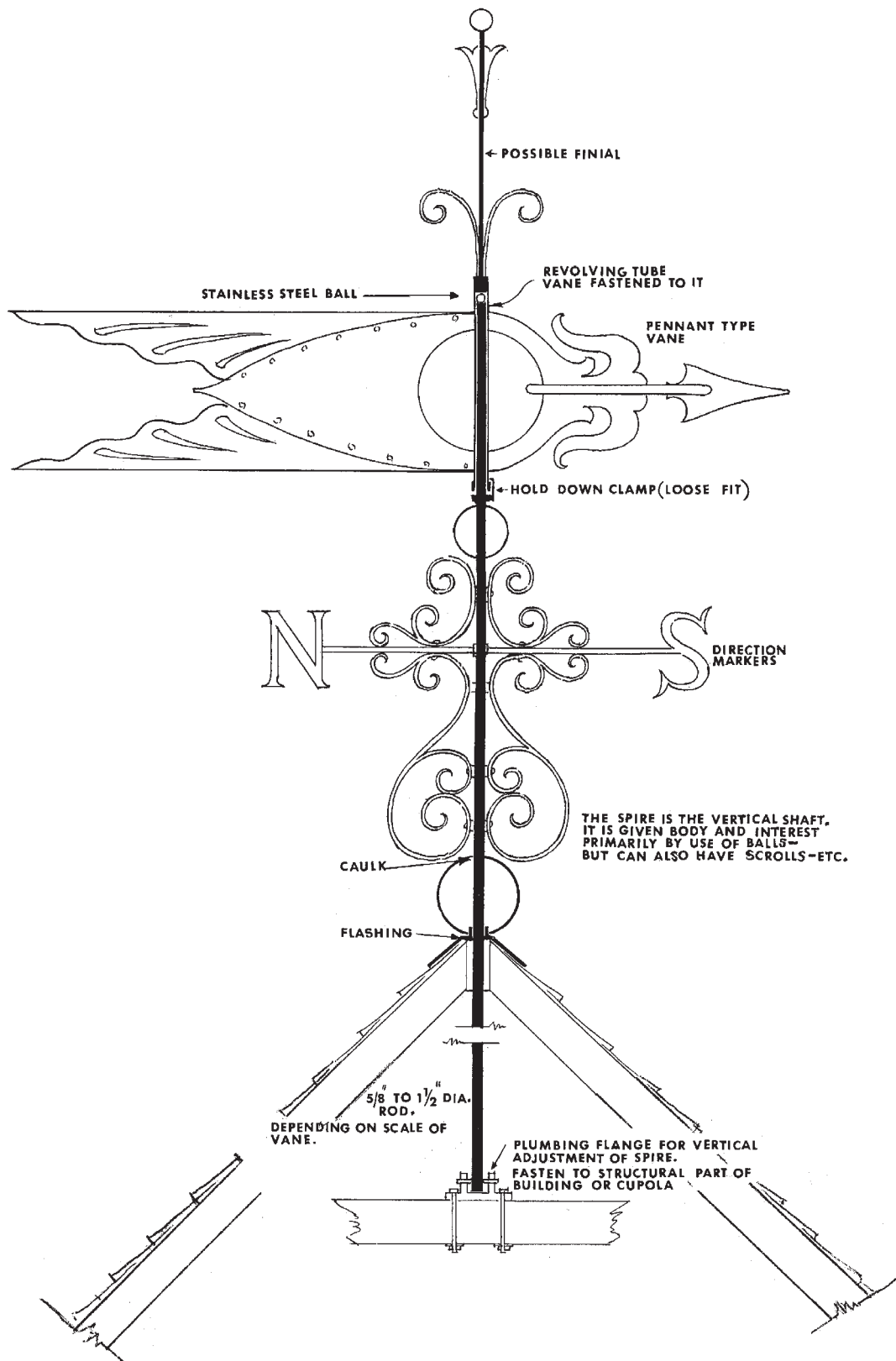

NO. 3826

The above cross section shows a typical weather vane installation, including the garnishment on the spire. In most cases, a weather vane must be at least 2" to 3" in length for each foot of elevation. However, this rule does not always apply and it is better to send in a drawing of the building and to mention your preference in a weather vane so that you can take advantage of our long experience and expert advice.

The further down inside of the building the spire can be anchored, naturally the stronger the weather vane is going to be. As a general rule, you should have an absolute minimum of half the outside length on the inside or 1/3 the total shaft length for anchoring. Shortening this space can lead to difficulty.

Note that we have a mounting flange at the bottom of the spire to anchor it, and for making the spire vertical. While normally many weather vanes only have the cardinal points of the compass, this illustration above shows clearly how much added interest one can achieve through the introduction of scrolls, balls, and similar garnishments. See illustration of the Old North Church Weather vane.

# WEATHERVANES

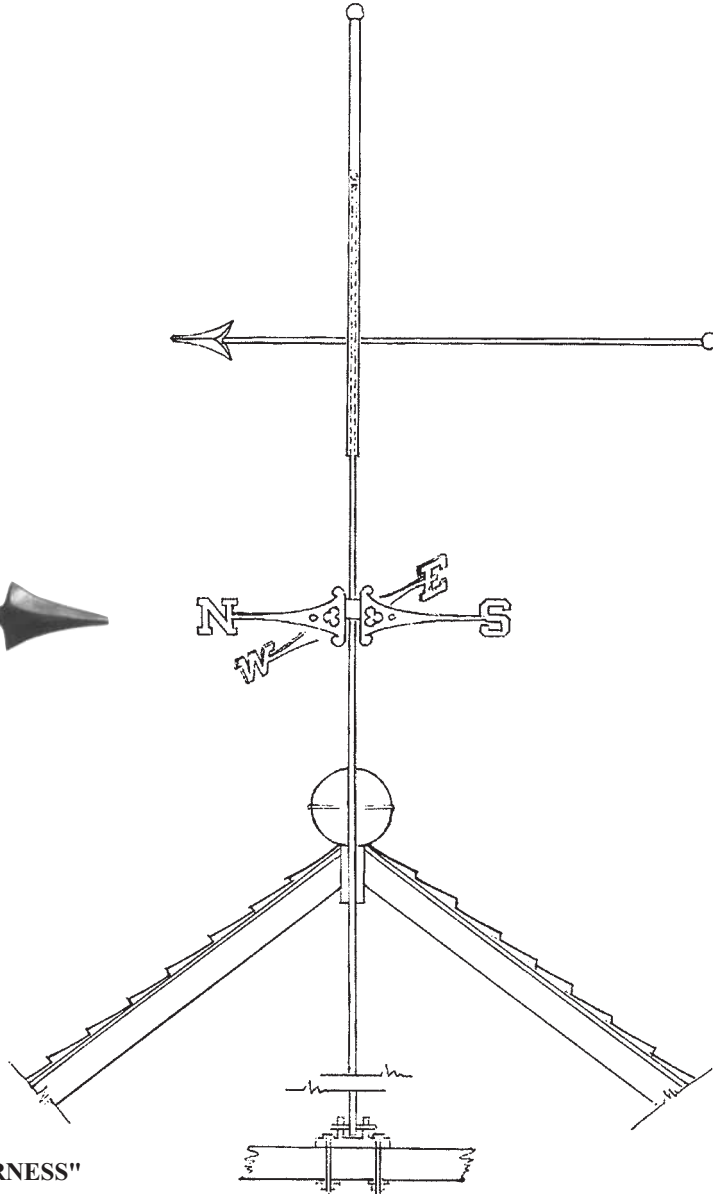
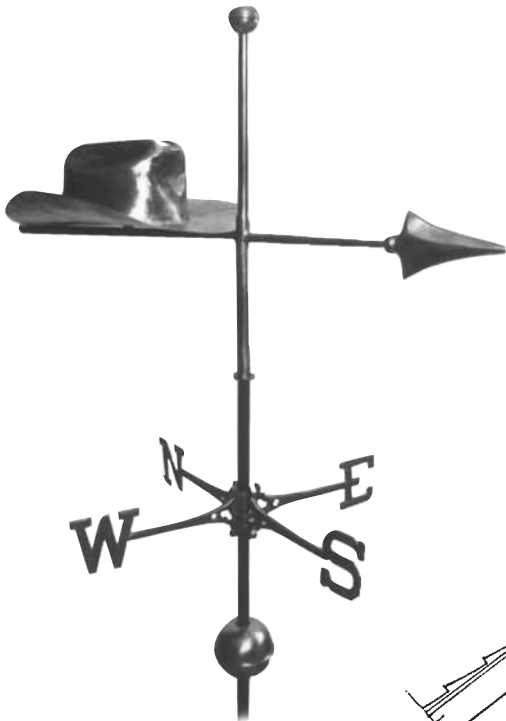

**NO. 3877**  
**"BASIC WEATHERVANE HARNESS"**  
 Stainless Steel  
 6'h with a 3/4" or 7/8" diameter shaft.

This is a complete unit ready to receive any silhouette-type motif. The silhouette must work as a silhouette and it must be able to be welded to the frame, shown above. It should make contact at the bottom bar and at least at one or two points along the vertical spire. Note illustration on page 396, (No. 3876). The carpenter's feet are resting at the bottom bar and the plane and scroll shaving rest on another member coming out from the spire. Poor practice would be to have an illustration such as a dog with his nose touching the spire as this would tend to deform the figure. Good judgement must be used.

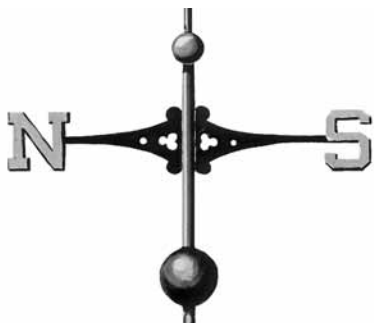

**NO. 3807**  
**"CARDINAL POINTS"**

LENGTH	LETTER HEIGHT	SPIRE DIA
22"	3 5/8"	7/8"
27"	5"	1"



**NO. 3804**  
**COPPER BALL**  
 2", 4", 5", 6", 8",  
 10" & 12" Diameter



**NO. 3875**  
**"CARDINAL POINT HOLDER"**  
 Stainless Steel  
 Hand made and special design

## CARDINAL POINTS

The above information refers to stock weathervane sizes only. For larger vanes, a shop drawing will be furnished showing the shaft size and letter size. Very large sizes and special scroll-type brackets "bespoke."



## WEATHERVANE ANCHORING INSTRUCTIONS

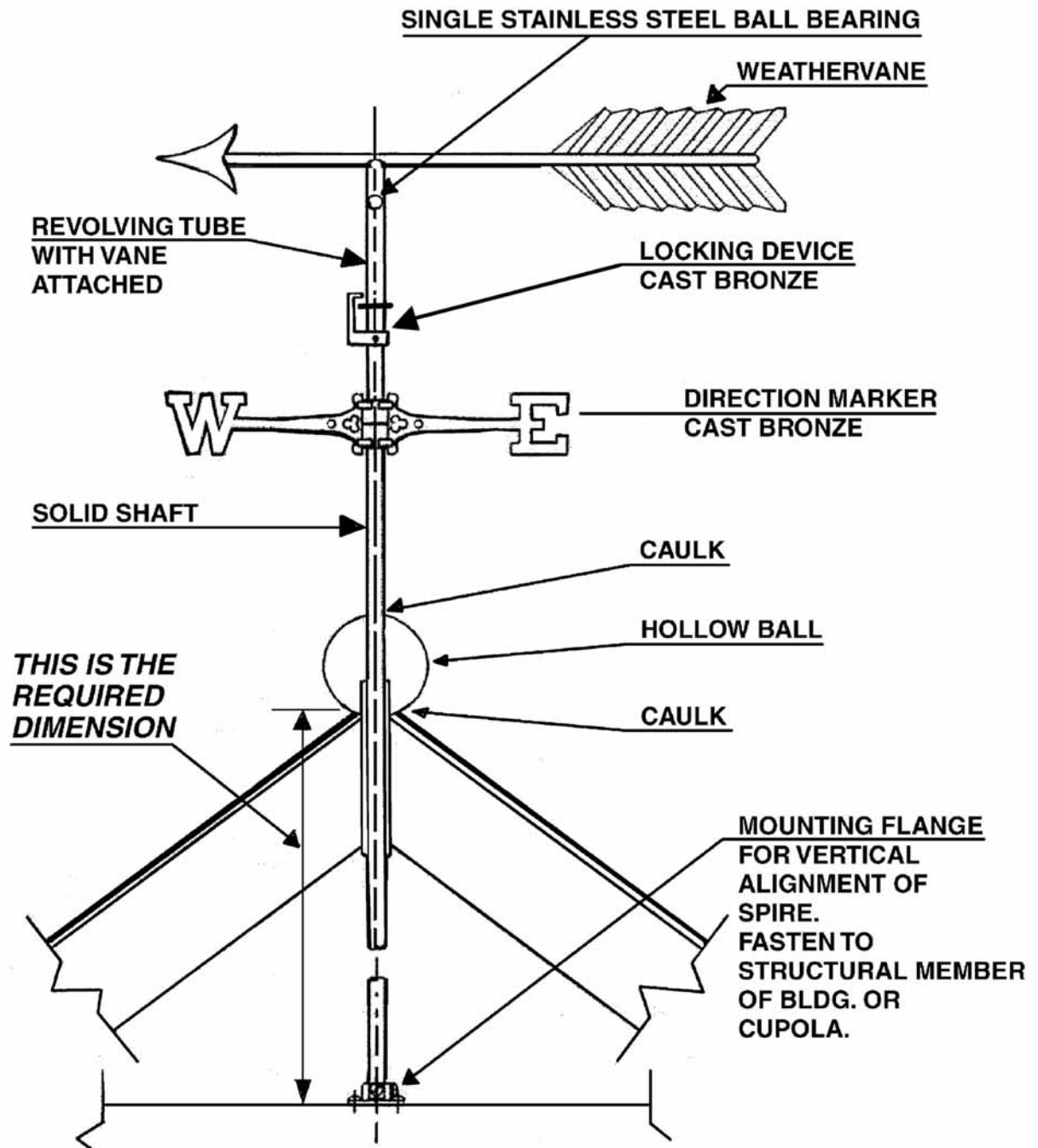

NO. 3827

Simple weathervane installation showing an ordinary arrow weathervane with the spire going down through to a collar beam. It is far better to have the weathervane a little oversized than it is to have it too small. Be sure to consider this advice when selecting the size for your weathervane. To make the shaft, we require the dimension shown.

# BESPOKE GARNITURES

On this page we show the wrought scroll-like members which are used to garnish a weathervane spire. Many of the tall spires used on older buildings had great masses of scrolls to decorate the spire and give it body. These are now all made of non-rusting materials and are ready to be introduced on any spire of the desired diameter. When we speak of a spire we refer only to the metal shaft that supports the weathervane, not the spire of a church building. In one of our older books on weathervanes it refers to these garnitures as being "Bespoke." This is an old English expression meaning that they are custom made to order, made to measure and fit. Therefore, all of these spire garnitures are "Bespoke."

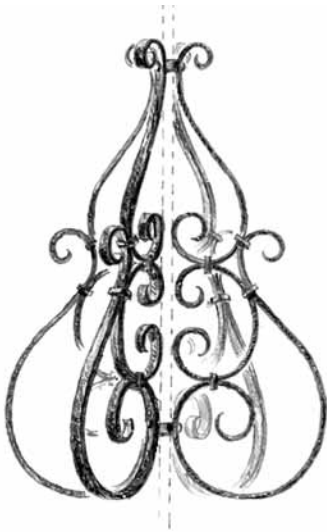

**NO. 3801**  
**BESPOKE GARNITURE**  
 Stainless Steel, 3'H

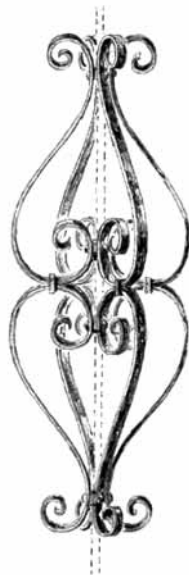

**NO. 3802**  
**BESPOKE GARNITURE**  
 Stainless Steel, 4'H

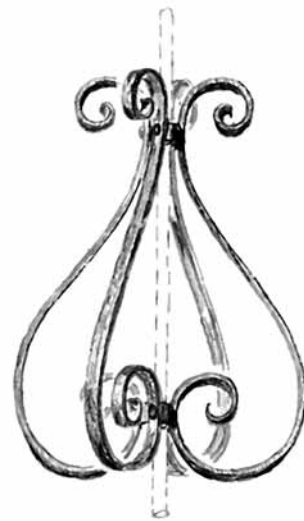

**NO. 3803**  
**BESPOKE GARNITURE**  
 Stainless Steel, 2'H

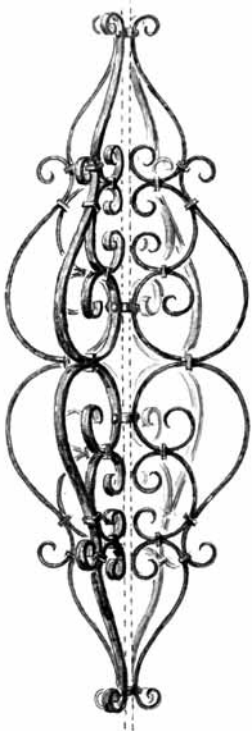

**NO. 3805**  
**BESPOKE GARNITURE**  
 Stainless Steel, 6'H

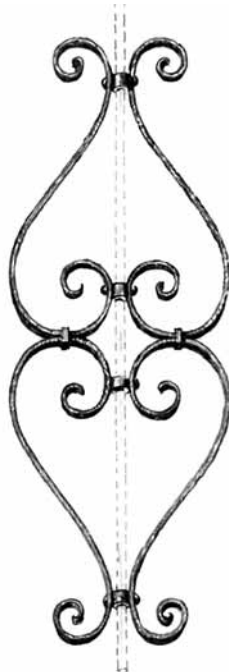

**NO. 3806**  
**BESPOKE GARNITURE**  
 Stainless Steel, 4'H

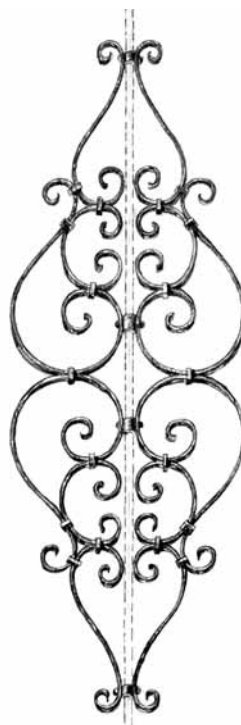

**NO. 3809**  
**BESPOKE GARNITURE**  
 Stainless Steel, 6'H

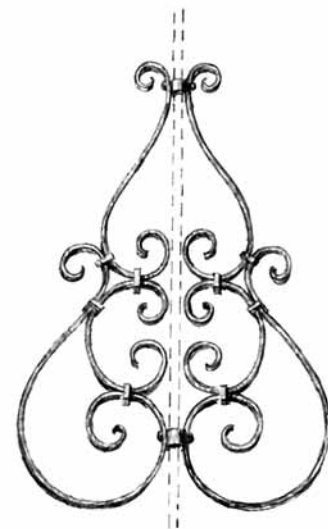

**NO. 3810**  
**BESPOKE GARNITURE**  
 Stainless Steel, 3'H





**NO. 2525 AMERICAN  
EAGLE VANE**

Copper  
18", 24", 30", 36",  
42", and 48" wingspan, other  
sizes on application.  
Plain, Gold Leaf or Verde Patina

NOTE:  
VERDE PATINA  
IS AVAILABLE  
FOR  
COPPER VANES  
ONLY.

**NO. 5576 INDIAN VANE**  
Copper, 36" H  
Plain, Gold Leaf or Verde Patina

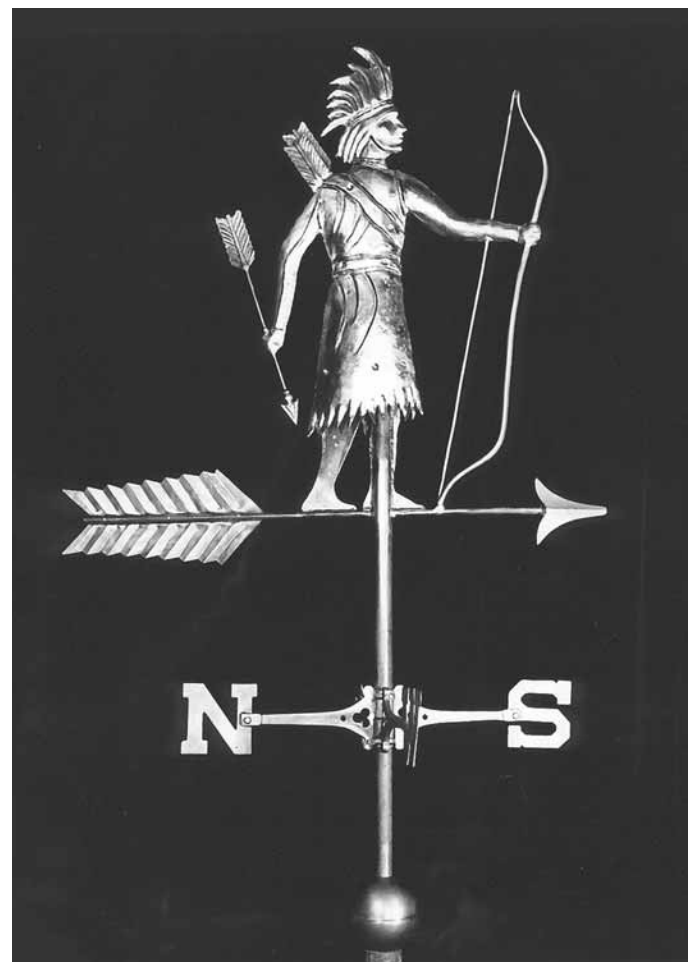

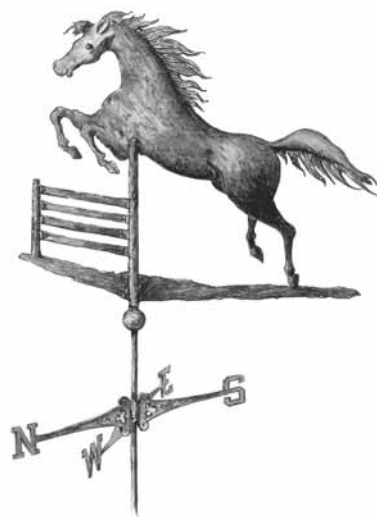
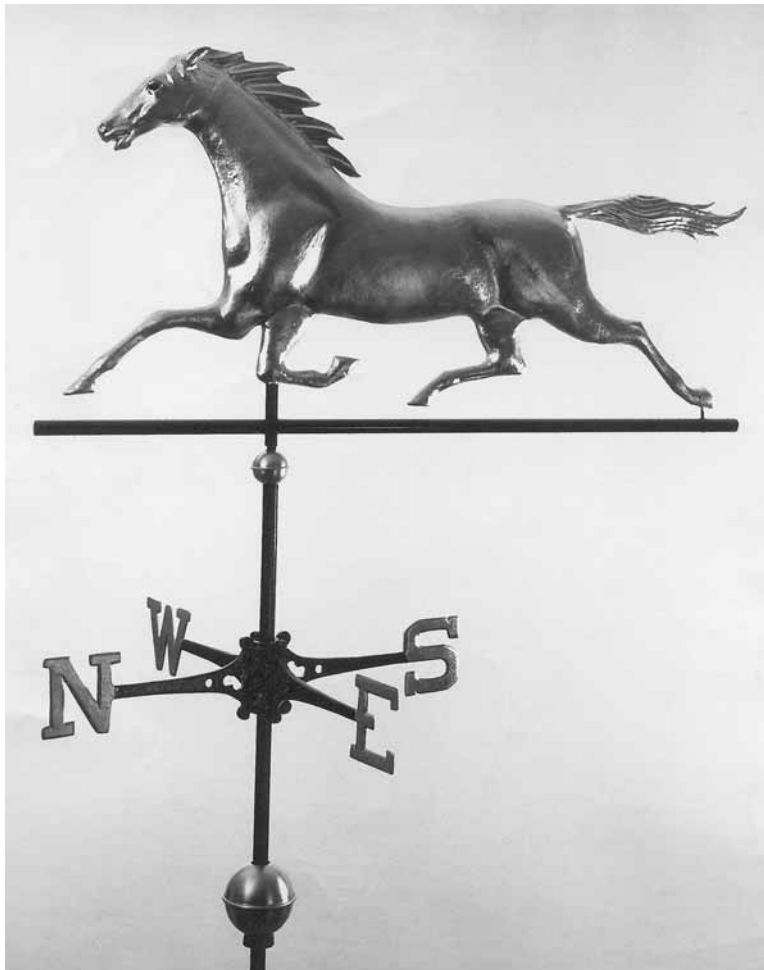

**NO. 3825 JUMPING HORSE VANE**  
 Aluminum, Copper or Stainless Steel, 48"L  
 Plain, Painted, Gold Leaf or Verde Patina

**NO. 1534 ETHAN ALLEN HORSE VANE**

Copper, 31"L

Plain, Gold Leaf or Verde Patina

We have made more of this horse weathervane than any other of similar design. We still have the same molds that we have been using for so many years. While this is certainly a middle 19th century piece of work, it has a rather primitive feeling to it and it is most attractive when on top of a barn.

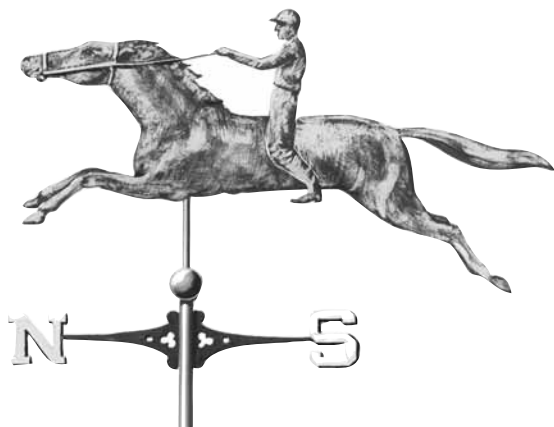

**NO. 1542 HORSE & JOCKEY VANE**

Copper, 32"L

Plain, Gold Leaf or Verde Patina

This is also available with the Jockey in the traditional position.

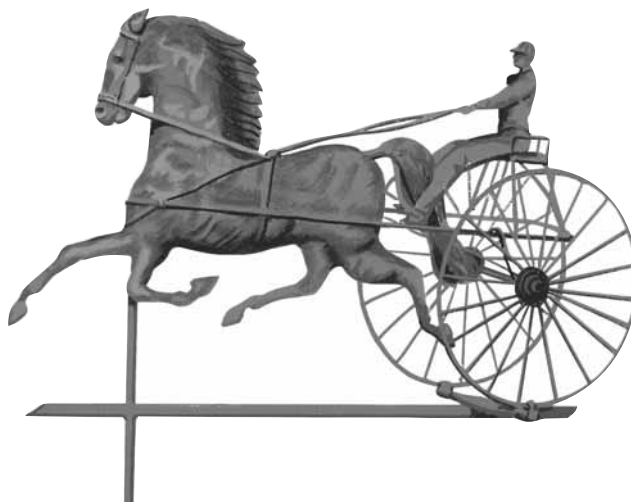

**NO. 1536 TROTTING HORSE & CART VANE**

Copper, 34"L

Plain, Gold Leaf or Verde Patina

Furnished in swell bodied. Several makers offered this during the 19th century. However, the above illustration is the best we have ever seen.



**NO. 2502 GOLFER VANE**  
Stainless Steel, 36"L  
Plain, Painted, or Gold Leaf

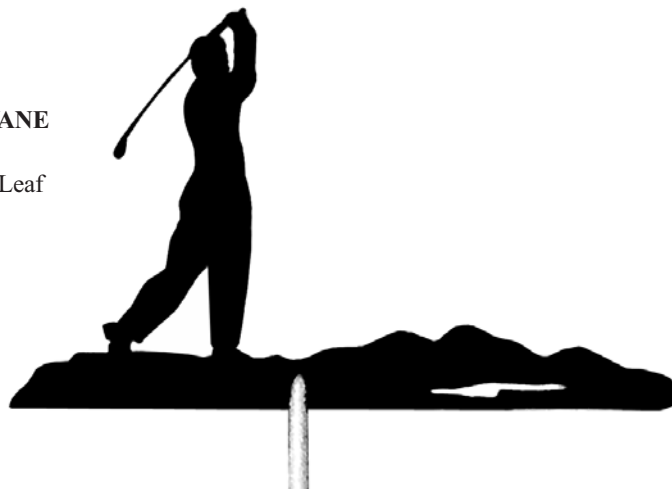

**NOTE:**  
SILHOUETTE  
WEATHERVANES  
CAN BE MADE IN  
ALUMINUM,  
COPPER OR  
STAINLESS STEEL.

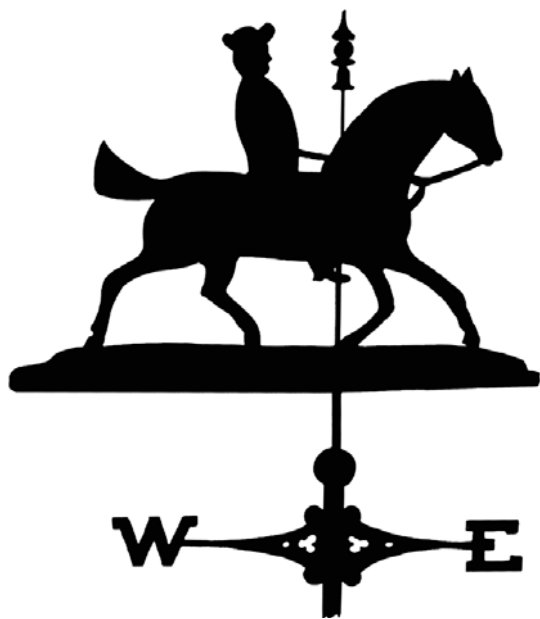

**NO. 2642 COLONIAL HORSE  
& RIDER VANE**  
Stainless Steel, 36"L  
Plain, Painted, or Gold Leaf

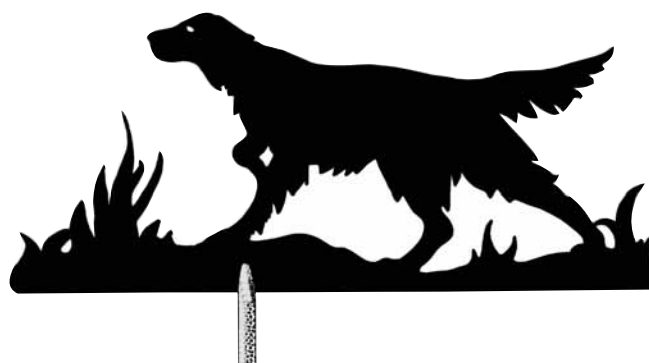

**NO. 2503 IRISH SETTER VANE**  
Stainless Steel, 36"L  
Plain, Painted, or Gold Leaf



**NO. 2021 MARY & HER LAMB VANE**  
Stainless Steel, 36"L  
Plain, Painted, or Gold Leaf

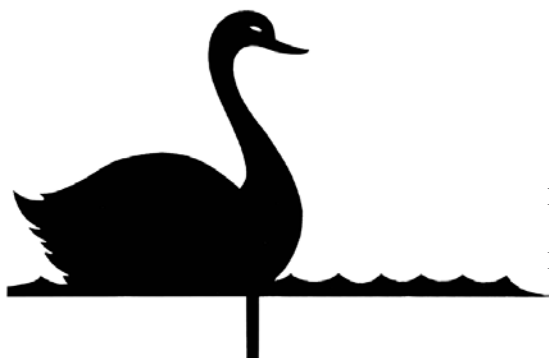

**NO. 2044 SWAN VANE**  
Stainless Steel, 36"L  
Plain, Painted, or Gold Leaf

# WEATHERVANES



**NO. 2001 VALKYRIE VANE**  
Stainless Steel, 36" L  
Plain, Painted, or Gold Leaf



**NO. 2002 NEPTUNE VANE**  
Stainless Steel, 36"L  
Plain, Painted, or Gold Leaf  
Neptune standing in a seashell, driving a horse on a wave-like base. Designed by Pierre Bourdelle and manufactured circa 1931 by Kenneth Lynch & Sons.



**NO. 2011 PLOUGHMAN VANE**  
Stainless Steel, 36"L  
Plain, Painted, or Gold Leaf



**NO. 2006 SWAN & CYGNET VANE**  
Stainless Steel, 36"L  
Plain, Painted, or Gold Leaf

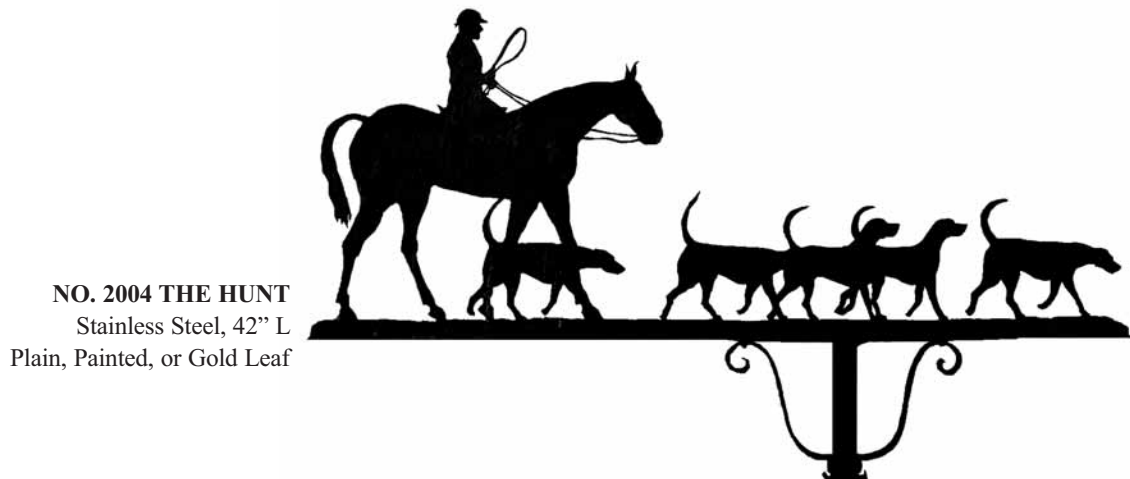

**NO. 2004 THE HUNT**  
Stainless Steel, 42" L  
Plain, Painted, or Gold Leaf



**NO. 2013 COLONIAL GENTLEMAN VANE**  
Stainless Steel, 36"L  
Plain, Painted, or Gold Leaf



**NO. 2019 GREEN PASTURES VANE**  
Stainless Steel, 36"L  
Plain, Painted, or Gold Leaf



**NO. 2020 "WISE OWLS" VANE**  
Stainless Steel, 36"L  
Plain, Painted, or Gold Leaf

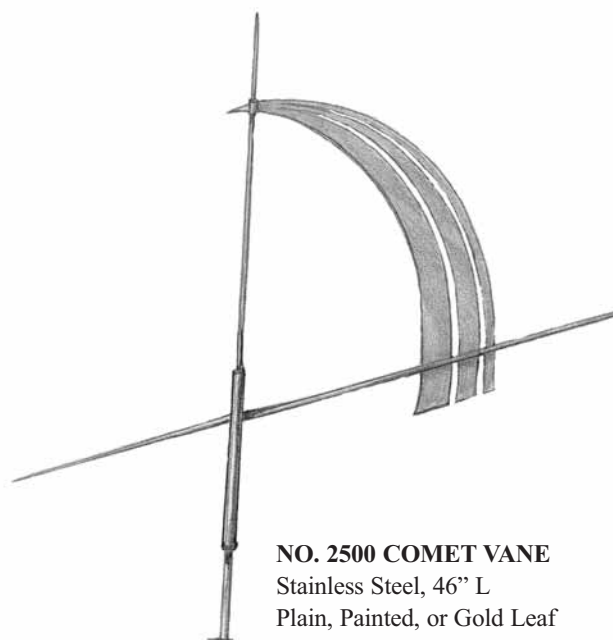

**NO. 2500 COMET VANE**  
Stainless Steel, 46" L  
Plain, Painted, or Gold Leaf

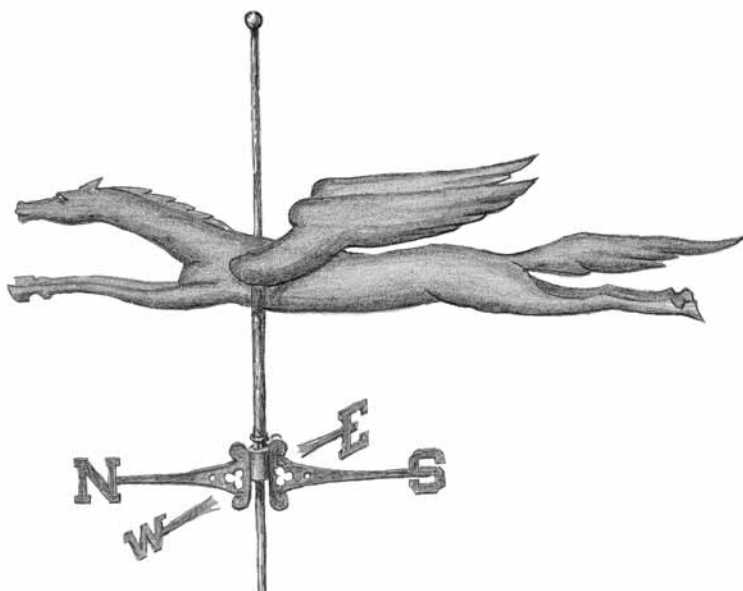

**NO. 3921 PEGASUS VANE**  
Stainless Steel, 36"L  
Plain, Painted, or Gold Leaf

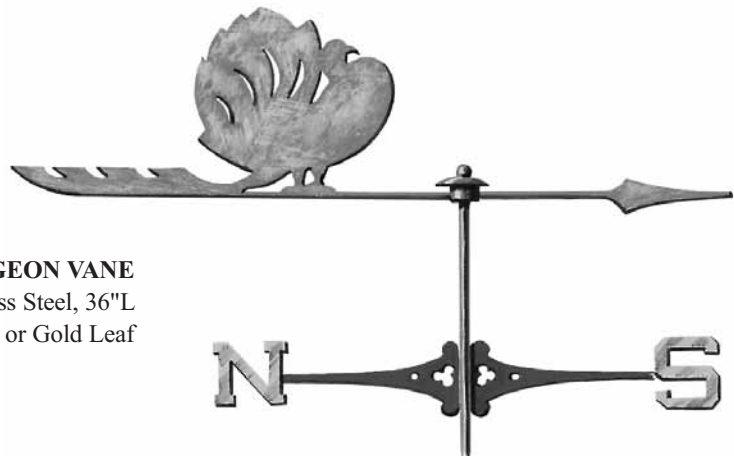

**NO. 2505 POUTER PIGEON VANE**  
 Aluminum or Stainless Steel, 36"L  
 Plain, Painted, or Gold Leaf



**NO. 2508 ROOSTER WITH  
 DOUBLE TAIL VANE**  
 Aluminum or Stainless Steel,  
 28"L  
 Plain, Painted, or Gold Leaf  
 Unusual design with double tail.

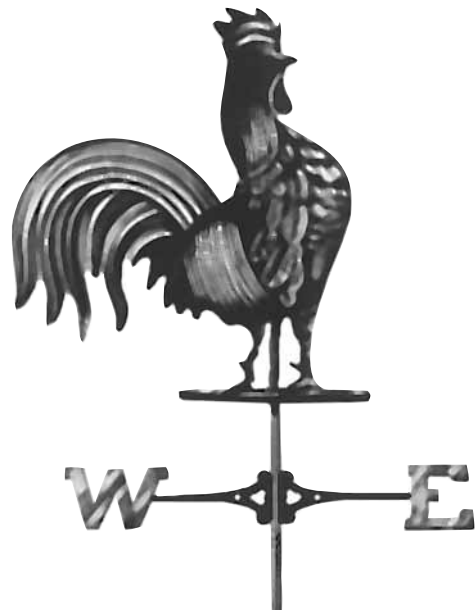

**NO. 2635 ROOSTER VANE**  
 Copper, 18", 24" or 30"H  
 Plain, Painted, Gold Leaf or Verde Patina

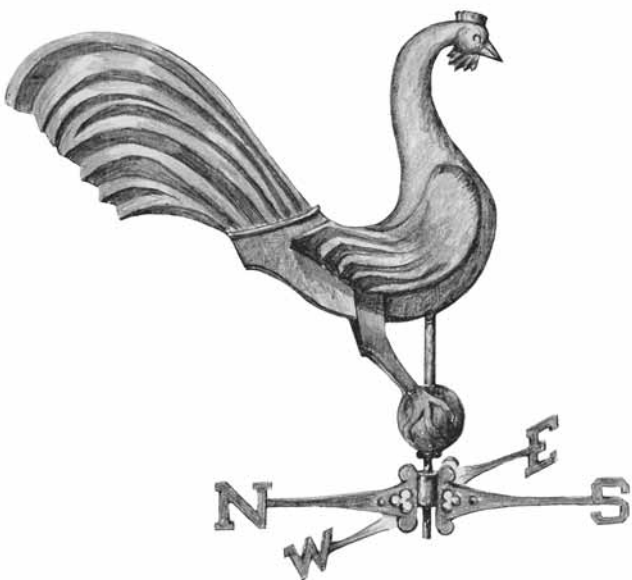

**NO. 3812 WEATHER COCK VANE**  
 Copper, 40"L  
 Plain, Gold Leaf or Verde Patina  
 Strikingly bold relief.

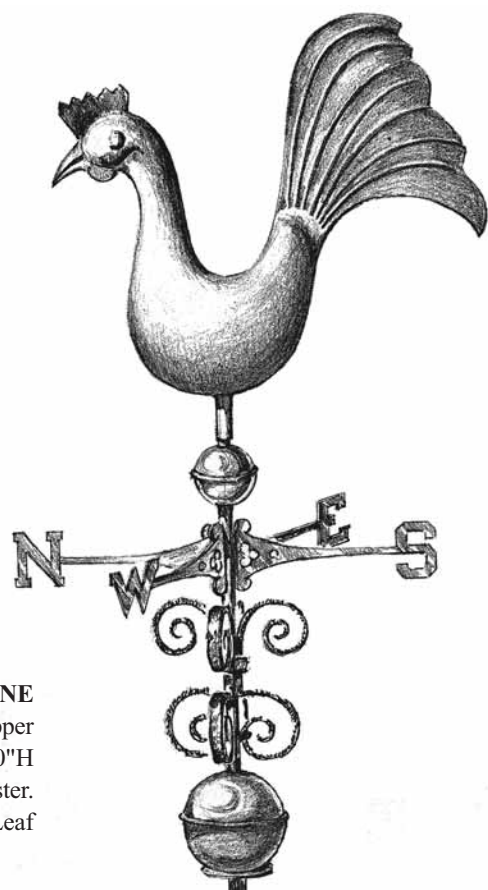

**NO. 4209 ROOSTER VANE**  
 Copper  
 Rooster is 30"H  
 Spire measures 60"H to underside of rooster.  
 Also available in Aluminum or Gold Leaf



NOTE:  
VERDE PATINA  
IS AVAILABLE  
FOR  
COPPER VANES  
ONLY.

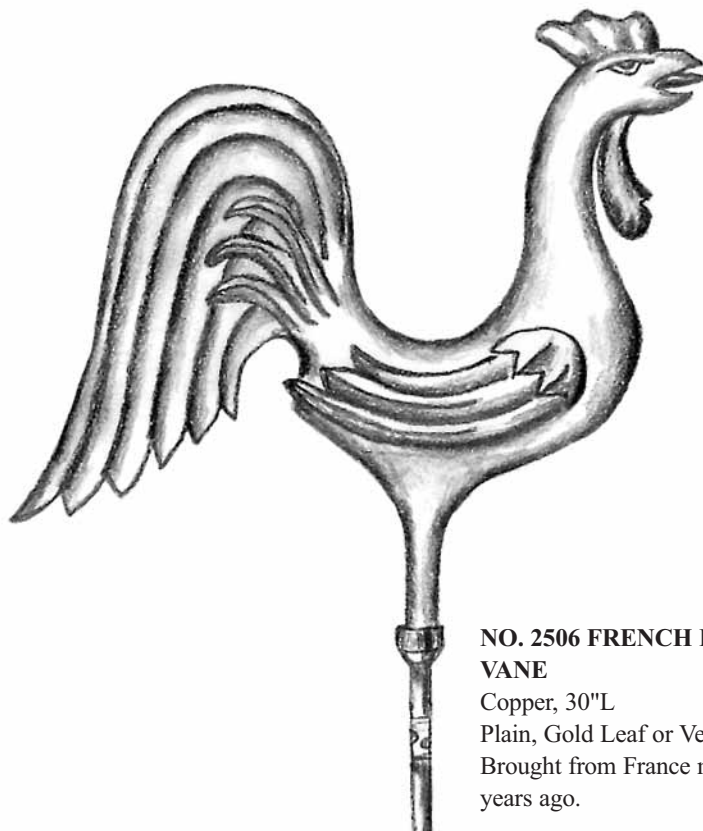

**NO. 2506 FRENCH ROOSTER VANE**  
Copper, 30"L  
Plain, Gold Leaf or Verde Patina  
Brought from France many years ago.

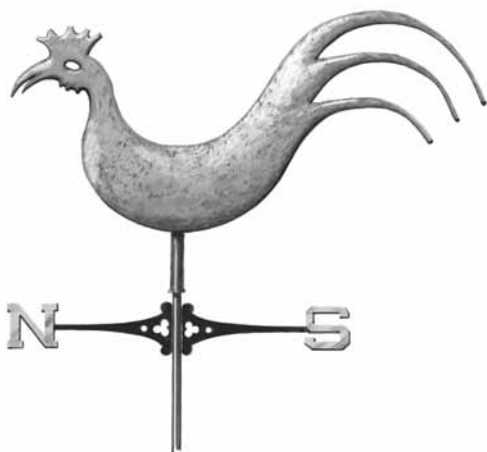

**NO. 2509 ROOSTER VANE**  
Aluminum or Stainless Steel as silhouette. Swell bodied copper on application, 28"L  
Plain, Painted, or Gold Leaf  
French antique reproduction.

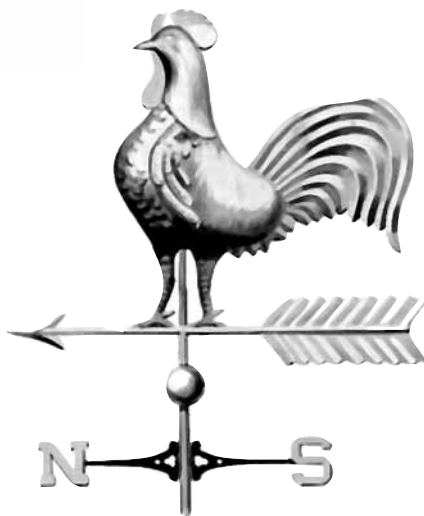

**NO. 1539 ROOSTER VANE**  
Copper, 18", 24", or 28"H  
Plain, Gold Leaf or Verde Patina  
This is furnished with the arrow. Old New England pattern.



**NO. 2510 WEATHER COCK VANE**  
Aluminum or Stainless Steel, 26"L  
Plain, Painted, or Gold Leaf



**NO. 2626 ROOSTER VANE**  
Aluminum or Stainless Steel, 34" L  
Plain, Painted, or Gold Leaf

# WEATHERVANES

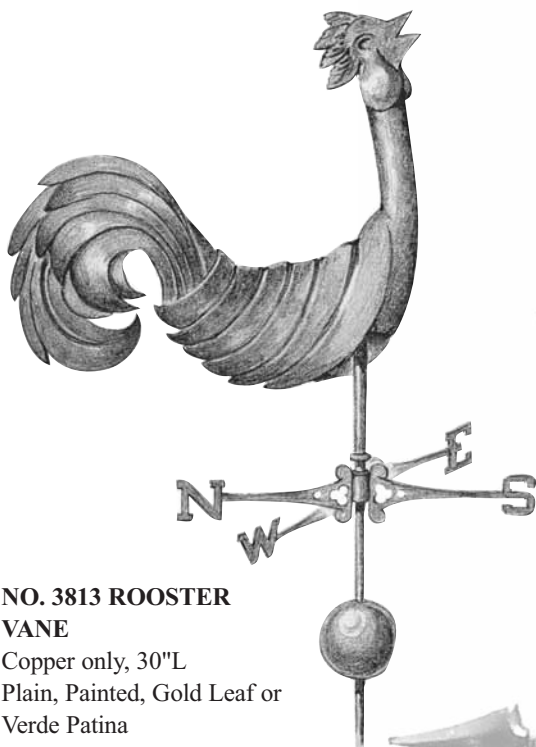

**NO. 3813 ROOSTER VANE**  
Copper only, 30"L  
Plain, Painted, Gold Leaf or Verde Patina



**NO. 3855 ROOSTER VANE**  
Copper, 36"L  
Plain, Painted, Gold Leaf or Verde Patina

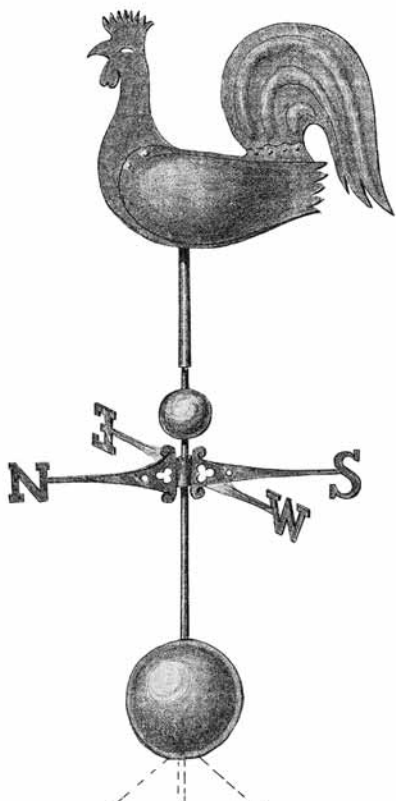

**NO. 3908 COCK VANE**  
Copper only, 36"L  
Plain, Gold Leaf or Verde Patina  
Made of several pieces riveted together. The wings are in bold relief, as is the tail.

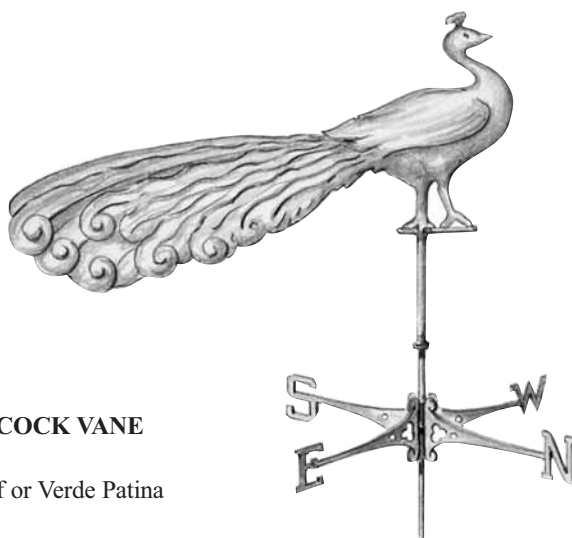

**NO. 3863 PEACOCK VANE**  
Copper, 36"L  
Plain, Gold Leaf or Verde Patina





**NO. 2420 RUNNING FOX VANE**  
Aluminum, Copper or Stainless Steel, 28"L  
Plain, Painted, Gold Leaf or Verde Patina

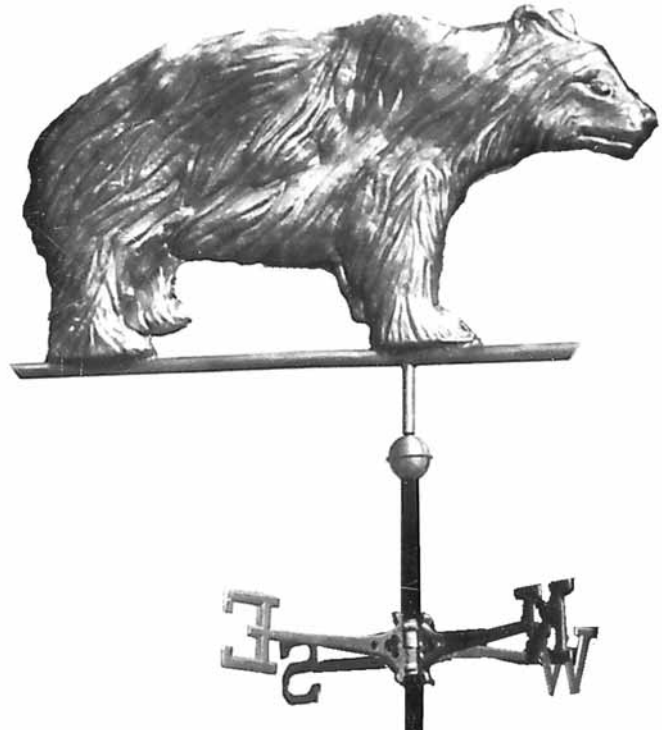

**NO 3164 BEAR VANE**  
Copper, 32"L  
From figure's nose to tail.  
Plain, Gold Leaf or Verde Patina

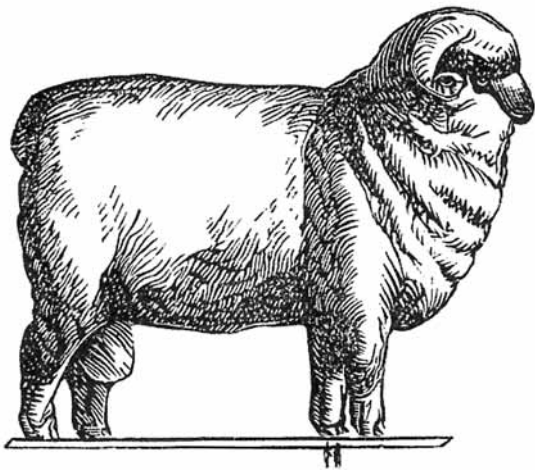

**NO. 3836 MERINO RAM VANE**  
Copper, 30 1/2"L figure.  
Plain, Gold Leaf or Verde Patina

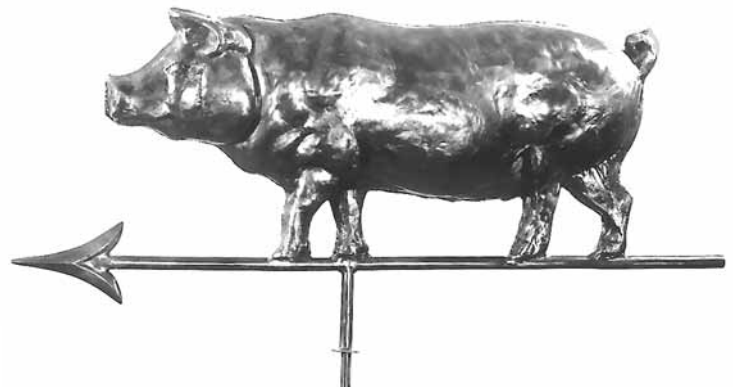

**NO. 3811 "PIG" VANE**  
Copper, Pig is 27"L,  
Overall length of Vane is 36" L  
(the length of Arrow)  
Plain, Gold Leaf or Verde Patina  
19th Century reproduction

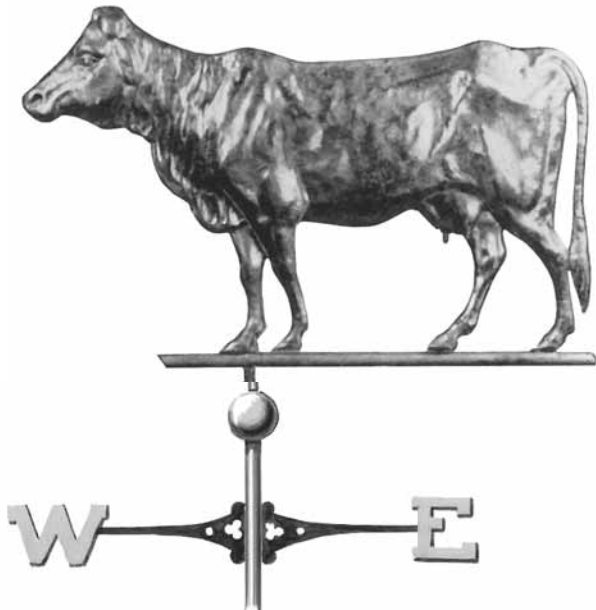

**NO. 1541 COW VANE**  
Copper, 28"L  
Plain, Gold Leaf or Verde Patina  
19th century

**NOTE:  
VERDE PATINA  
IS AVAILABLE  
FOR  
COPPER VANES  
ONLY.**

# WEATHERVANES



**NO. 5574 HORSE VANE**  
Copper, 42" L  
Plain, Gold Leaf or Verde Patina

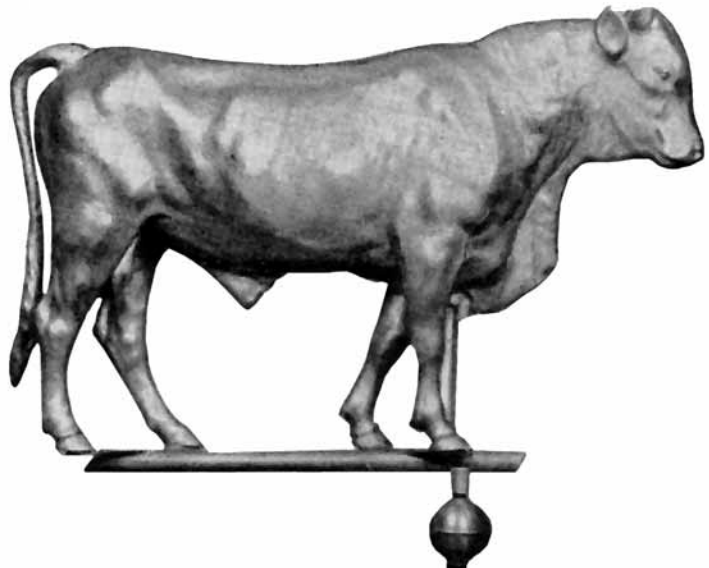

**NO. 1538 BULL VANE**  
Copper, 28" L  
Plain, Gold Leaf or Verde Patina.  
19th century.



**NO. 3832 PRIMITIVE HORSE VANE**  
Copper, 40" L  
Plain, Gold Leaf or Verde Patina



**NO. 2632 ANGEL AND HORN VANE**  
Aluminum only, 40" L  
Painted and some parts are Gold Leafed; horn, hair and indicators. Flesh colored body, white wings and blue painted ribbon on horn and around the figure.

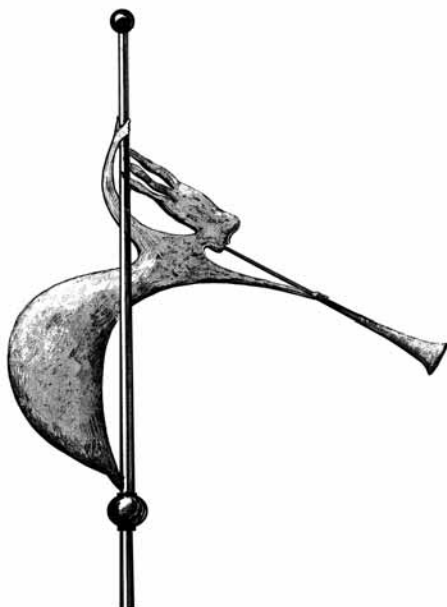

**NO. 2636 ANGEL WITH HORN VANE**  
Copper  
38" H figure X 40" L  
Plain, Painted, Gold Leaf or Verde Patina

**NOTE:  
VERDE PATINA  
IS AVAILABLE  
FOR  
COPPER VANES  
ONLY.**

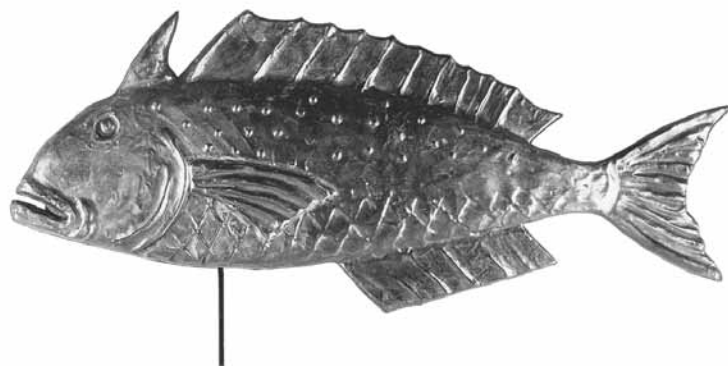

**NO. 3907 FISH VANE**  
Copper, 30" L  
Plain, Gold Leaf or Verde Patina  
This design is based on the Tile fish of Cape Cod.

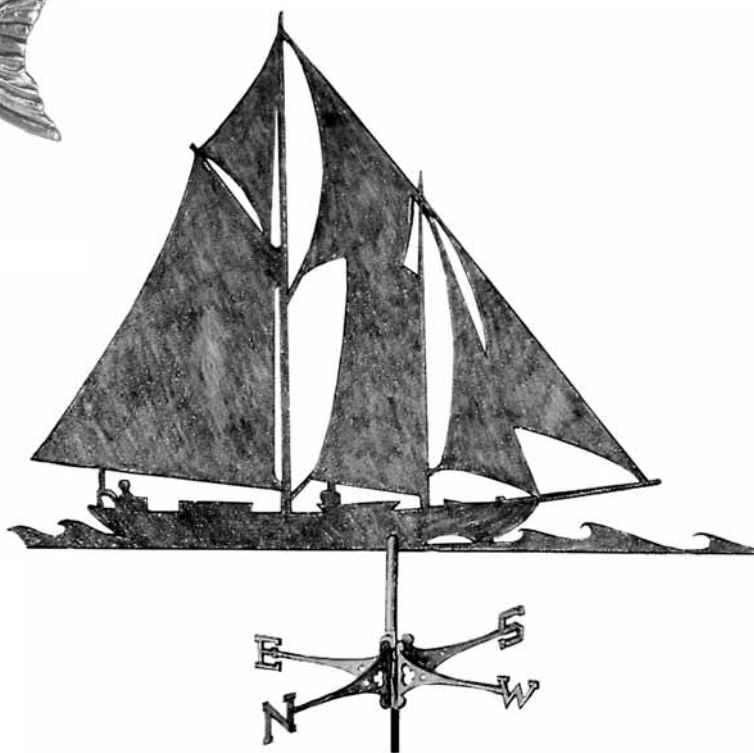

**NO. 4118 GAFF RIGGED SCHOONER VANE**  
Aluminum or Stainless Steel,  
36" L, Custom length available  
Silhouette only.  
Plain, Painted or Gold Leaf



**NO. 2514 WHALE WITH SPOUT VANE**  
Aluminum or Stainless Steel, 30" L  
Silhouette only.  
Plain, Painted or Gold Leaf  
Antique reproduction.

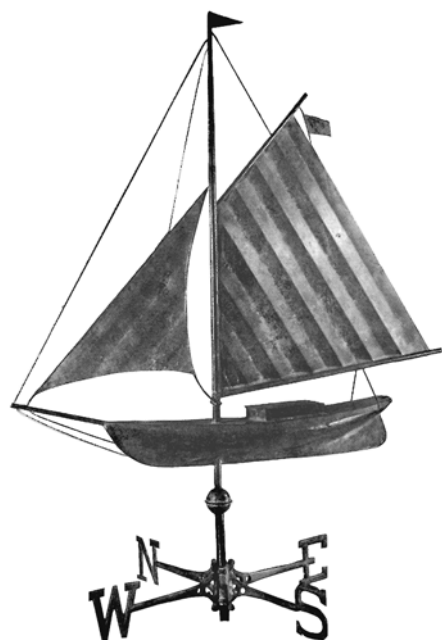

**NO. 2511 SLOOP VANE**  
Copper, 36" L  
Plain, Gold Leaf or Verde Patina



**NO. 3912 SEA CAPTAIN VANE**  
Aluminum or Stainless Steel  
36" H  
Plain, Painted, or Gold Leaf

# WEATHERVANES



**NO. 2625 SWORDFISH VANE**  
 Aluminum or Stainless Steel, 36"L  
 Silhouette only.  
 Plain, Painted, or Gold Leaf

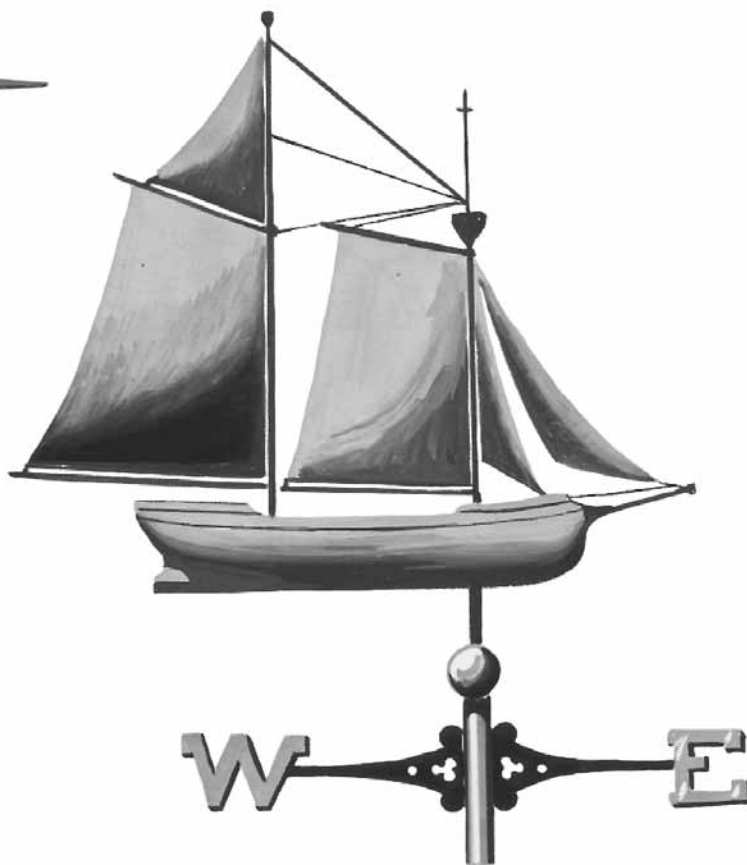

**NO. 1537 SCHOONER VANE**  
 Copper, 36"L  
 Plain, Gold Leaf or Verde Patina  
 All hand made.



**NO. 50A SEA CAPTAIN WITH SCOTTIE DOG VANE**  
 Copper, 60"L X 34"H  
 Can be made in any size as this is a silhouette.

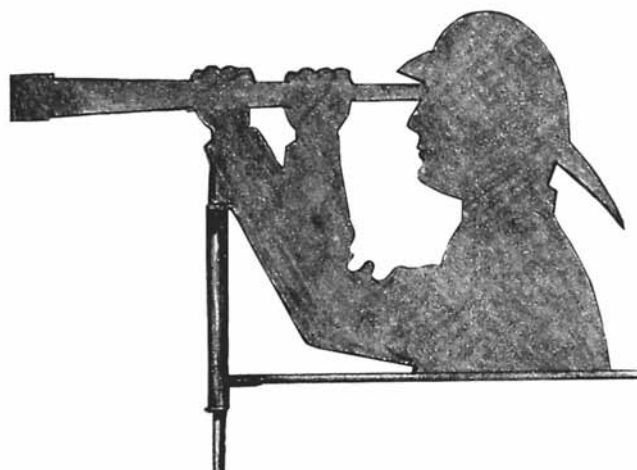

**NO. 2515 SOU'WESTER VANE**  
 Aluminum, Copper or Stainless Steel, 26"L  
 Silhouette only.  
 Plain, Painted, Gold Leaf or Verde Patina

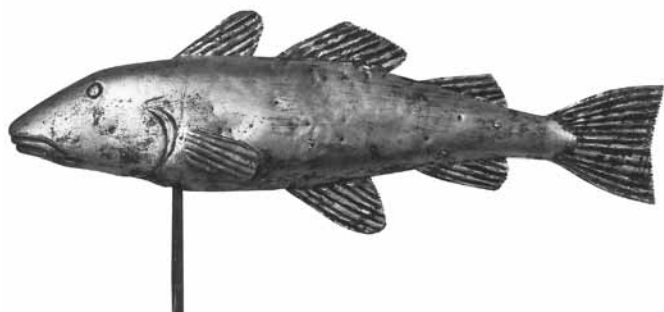

**NO. 3838 PRIMITIVE FISH VANE**  
 Copper, 36"L  
 Plain, Gold Leaf or Verde Patina



**NO. 2653 PEG LEG VANE**  
Aluminum or Stainless Steel, 6"L  
Silhouette only.  
Plain, Painted, Gold Leaf or Verde Patina

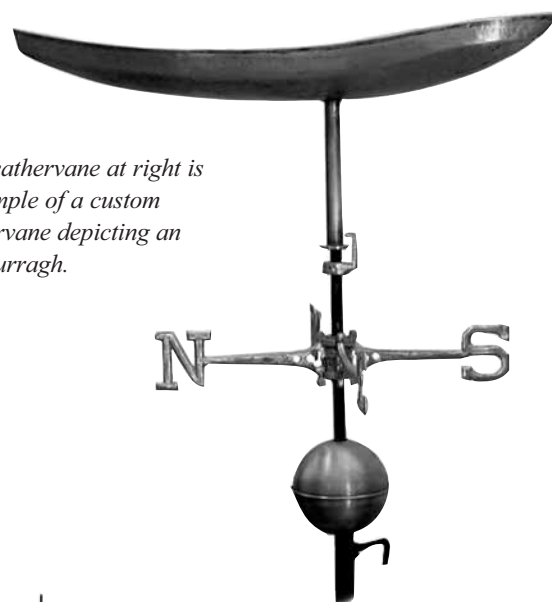

*This weathervane at right is an example of a custom weathervane depicting an Irish Curragh.*

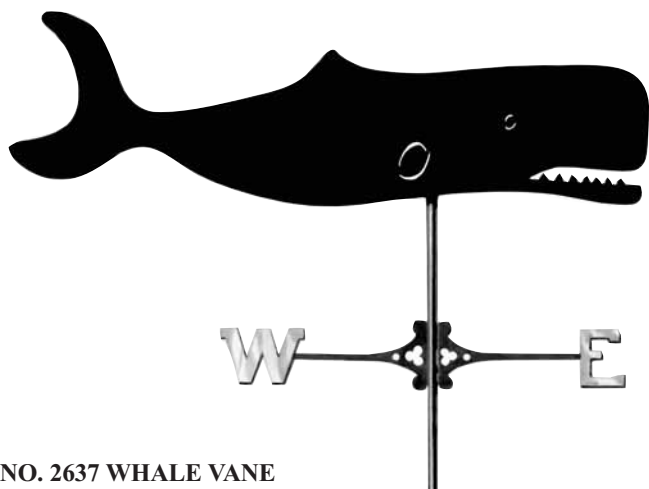

**NO. 2637 WHALE VANE**  
Aluminum or Stainless Steel  
34"L  
Plain, Painted, or Gold Leaf

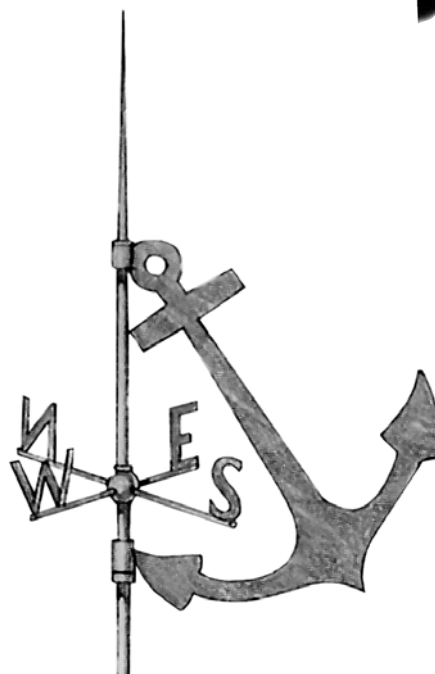

**NO. 2512 ANCHOR TO LEEWARD VANE**  
Aluminum, Copper or Stainless Steel, 24"  
Silhouette only.  
Plain, Painted, Gold Leaf or Verde Patina



**NO. 2638 MERMAID VANE**  
Aluminum only  
40"L  
Plain, Painted and hair, mirror and comb are always Gold Leafed.

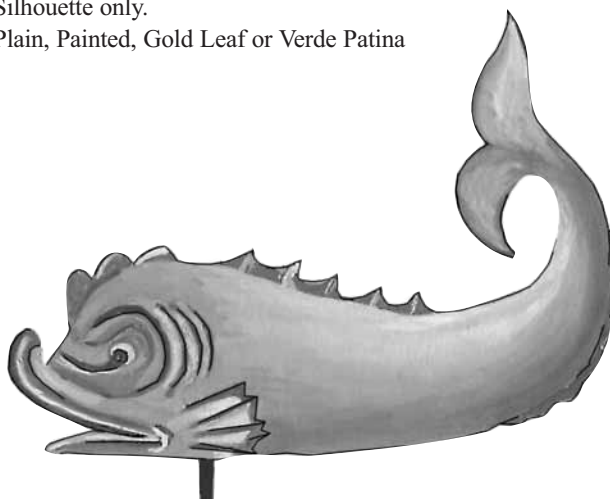

**NO. 2639 DOLPHIN VANE**  
Aluminum only  
30"L  
Plain, Painted, or Gold Leaf

# ZODIAC WEATHERVANES

Zodiac weathervanes have become so popular that we have done a special sheet on them. They are in silhouette only and are made of Stainless Steel. They are generally painted black or gilded and measure 36" overall. The 36" measurement is from the tip of the arrow to the ball terminal. They come complete with cardinal points.

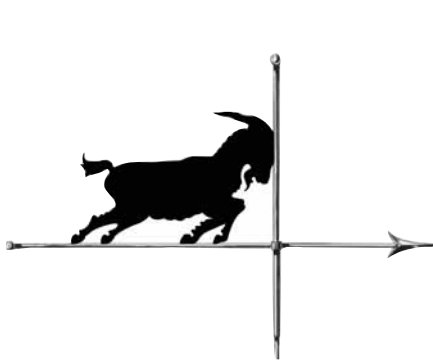

**NO. 2673 "CAPRICORN"  
(THE GOAT)**  
Stainless Steel  
36"L  
Plain, Painted, or Gold Leaf

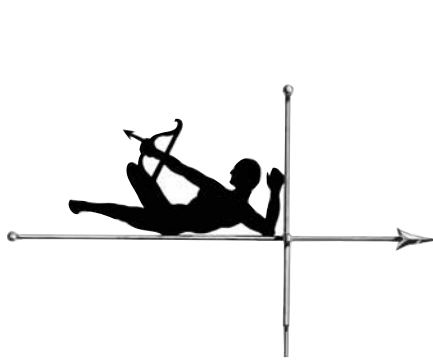

**NO. 2674 "SAGITARIUS"  
(THE ARCHER)**  
Stainless Steel  
36"L  
Plain, Painted, or Gold Leaf

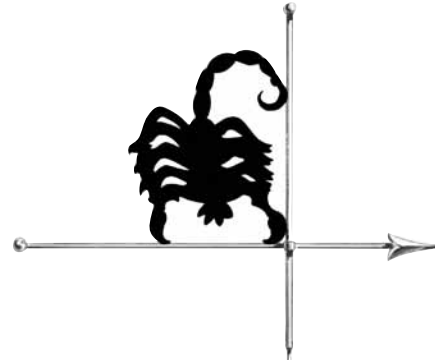

**NO. 2675 "SCORPIO"  
(THE SCORPION)**  
Stainless Steel  
36"L  
Plain, Painted, or Gold Leaf



**NO. 2676 "LIBRA" (THE SCALES)**  
Stainless Steel  
36"L  
Plain, Painted, or Gold Leaf

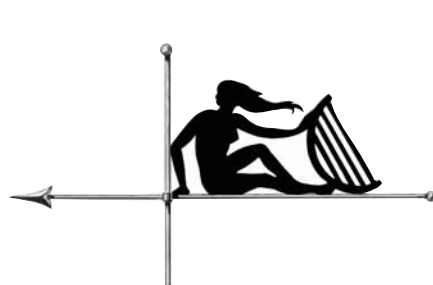

**NO. 2677 "VIRGO" (THE VIRGIN)**  
Stainless Steel  
36"L  
Plain, Painted, or Gold Leaf

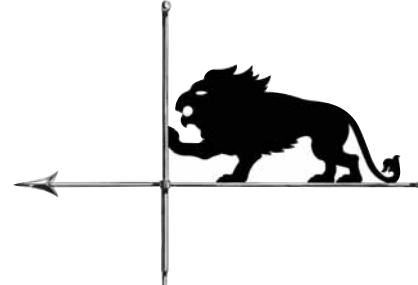

**NO. 2678 "LEO" (THE LION)**  
Stainless Steel  
36"L  
Plain, Painted, or Gold Leaf

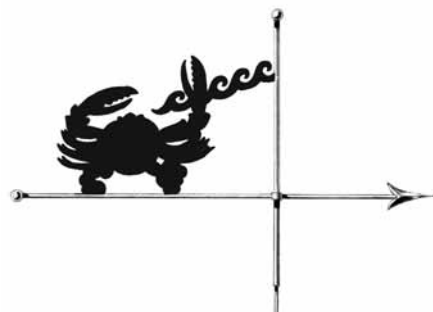

**NO. 2679 "CANCER" (THE CRAB)**  
Stainless Steel  
36"L  
Plain, Painted, or Gold Leaf

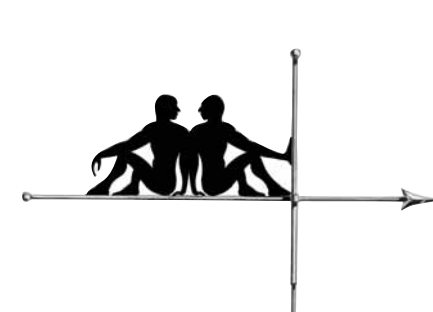

**NO. 2680 "GEMINI" (THE TWINS)**  
Stainless Steel  
36"L  
Plain, Painted, or Gold Leaf



**NO. 2681 "TAURUS" (THE BULL)**  
Stainless Steel  
36"L  
Plain, Painted, or Gold Leaf

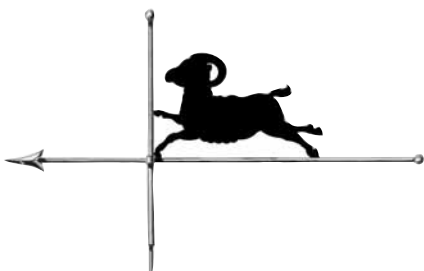

**NO. 2682 "ARIES" (THE RAM)**  
Stainless Steel  
36"L  
Plain, Painted, or Gold Leaf

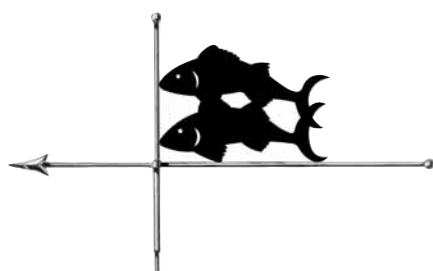

**NO. 2683 "PISCES" (THE FISHES)**  
Stainless Steel  
36"L  
Plain, Painted, or Gold Leaf

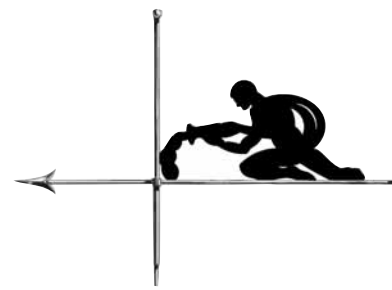

**NO. 2684 "AQUARIUS"  
(THE WATER BEARER)**  
Stainless Steel  
36"L  
Plain, Painted, or Gold Leaf



**NO. 3172 POLO PLAYER VANE**  
Copper, 48" L  
Plain, Gold Leaf or Verde Patina

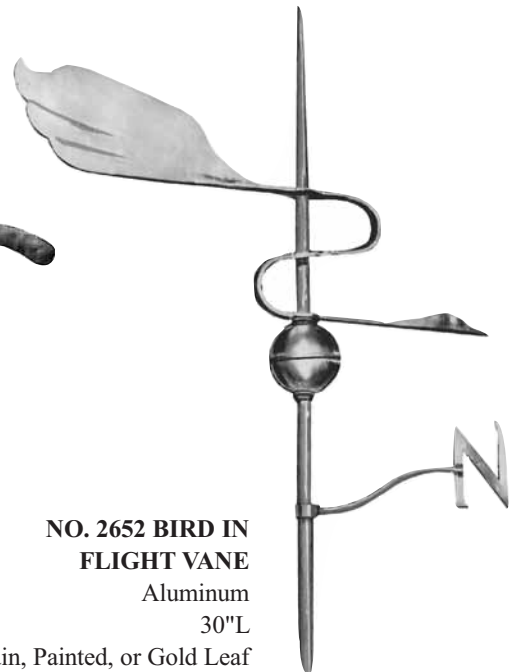

**NO. 2652 BIRD IN FLIGHT VANE**  
Aluminum  
30" L  
Plain, Painted, or Gold Leaf

NOTE:  
VERDE PATINA  
IS AVAILABLE  
ON  
COPPER  
ONLY.



**NO. 3135 TENNIS PLAYER VANE**  
Copper, 30" H  
Plain, Gold Leaf or Verde Patina



**NO. 3163A 19TH CENTURY DRAGON VANE**  
Special order

# WEATHERVANES

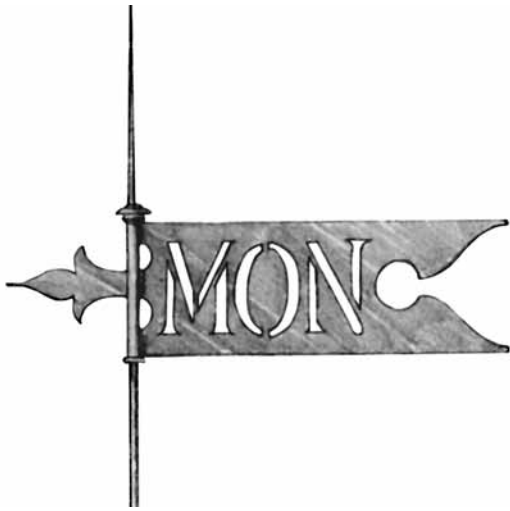

**NO. 2501 BANNER VANE**  
 Aluminum, Copper or Stainless Steel, 36" L  
 Plain, Painted, Gold Leaf or Verde Patina  
 Manufactured with any monogram.

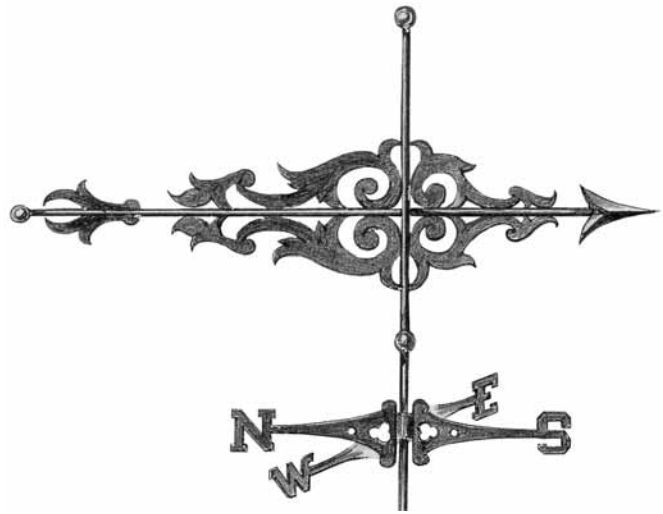

**NO. 3995 19TH CENTURY BANNER VANE**  
 Aluminum, Copper or Stainless Steel, 40" L  
 Plain, Painted, Gold Leaf or Verde Patina

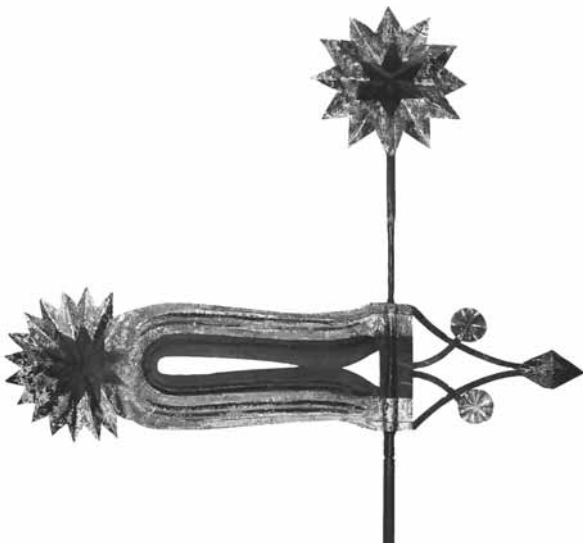

**NO. 3844 BLAZING STAR VANE**  
 Copper, 40" L  
 Plain, Gold Leaf or Verde Patina  
 Colonial Williamsburg Collection.

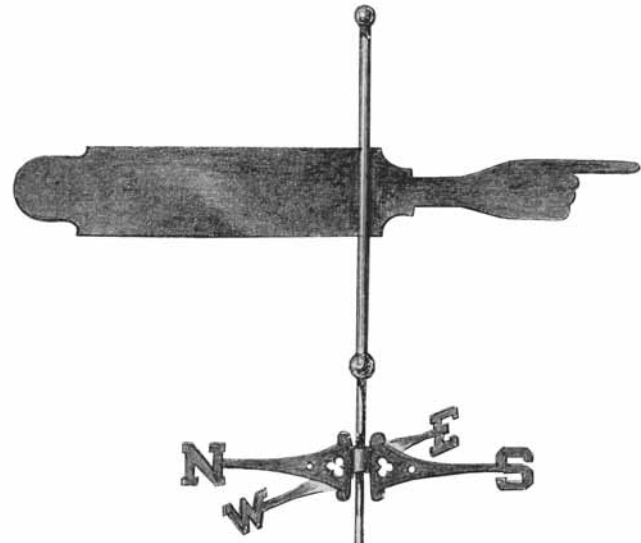

**NO. 3891 ARM & POINTING HAND VANE**  
 Aluminum or Stainless Steel, 40" L  
 Plain, Painted, or Gold Leaf

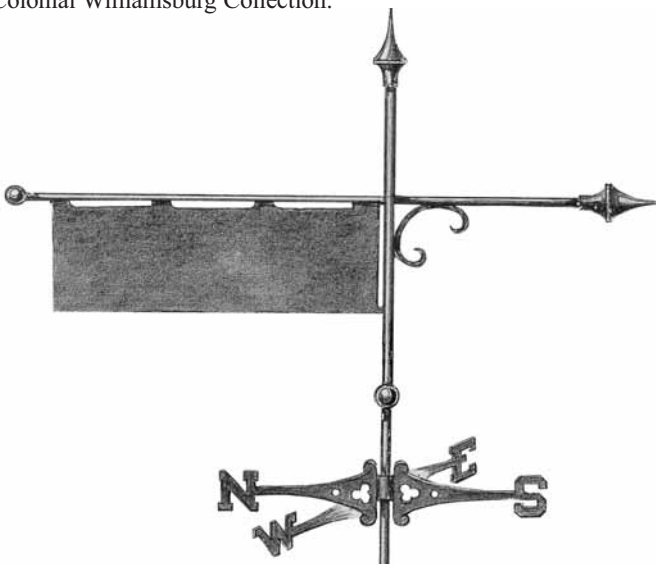

**NO. 3993 BANNERETTE VANE**  
 Aluminum, Copper or Stainless Steel, 40" L  
 Plain, Painted, Gold Leaf or Verde Patina  
 Reproduction of the U.S. Army Headquarters, Governors Island,  
 New York. The vane can be inscribed.



**NO. 3996 BANNNER SILHOUETTE VANE**  
 Aluminum, Copper or Stainless Steel, 48" L  
 Plain, Painted, Gold Leaf or Verde Patina  
 May be inscribed.



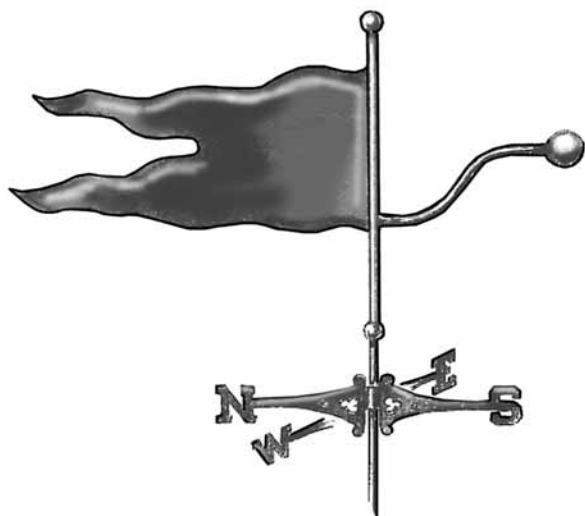

**NO. 3997 BANNER VANE**  
Aluminum, Copper or Stainless Steel, 46" L  
Plain, Painted, Gold Leaf or Verde Patina  
Vane with balancing counter weight in spherical shape.

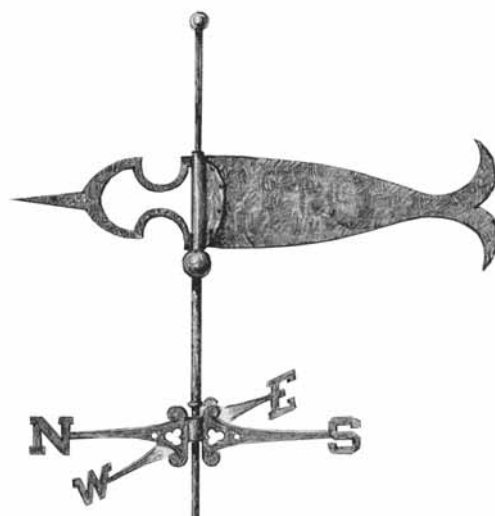

**NO. 3814 STYLIZED SWORDFISH VANE**  
Aluminum, Copper or Stainless Steel, 40"L  
Plain, Painted, Gold Leaf or Verde Patina  
The designer was inspired by an antique vane he had seen.

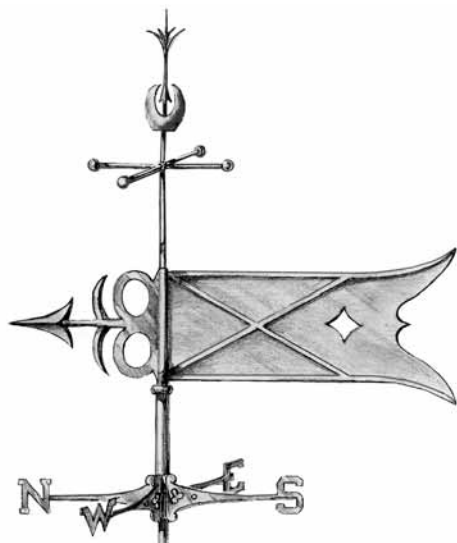

**NO. 2629 BANNER VANE**  
Aluminum, 34" L  
Plain, Painted, or Gold Leaf  
*Copper with Verde Patina finish on special orders only.*  
*Our most popular banner vane; usually kept in stock.*

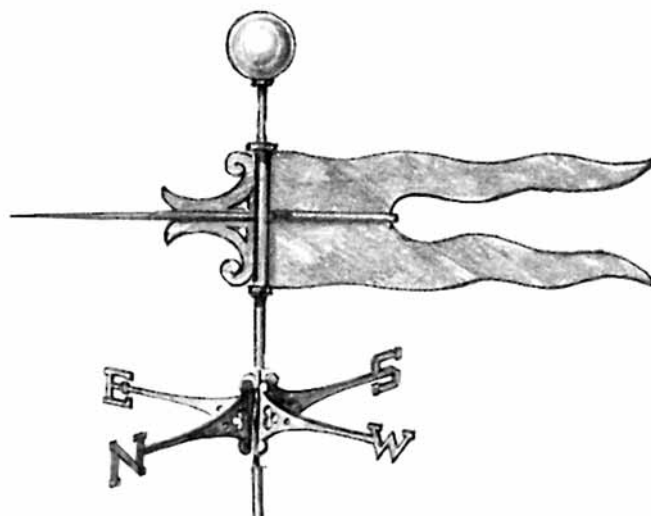

**NO. 2504 BANNERETTE VANE**  
Aluminum or Stainless Steel, 36"L  
Plain, Painted, or Gold Leaf

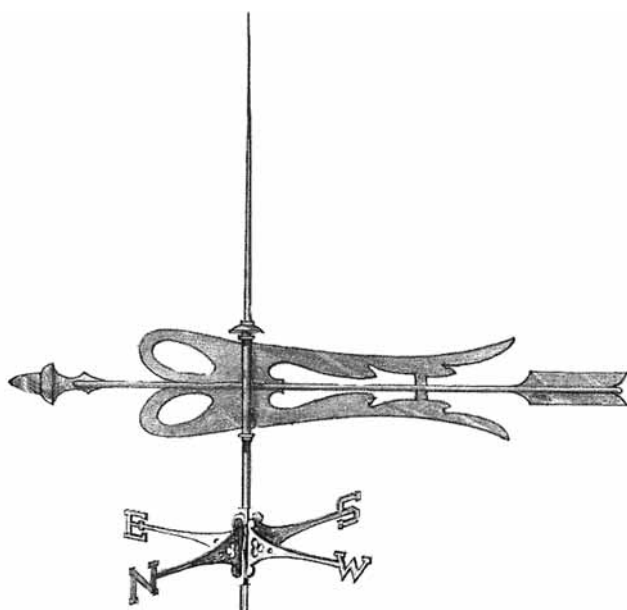

**NO. 2526 WINGED ARROW VANE**  
Aluminum or Stainless Steel, 32"L  
Plain, Painted, or Gold Leaf

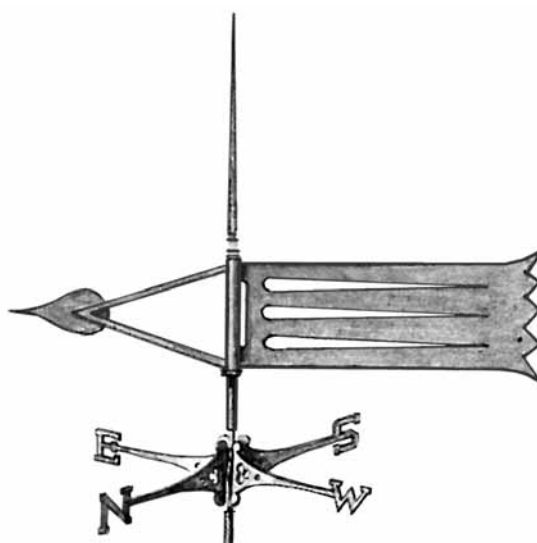

**NO. 2527 TUDOR BANNER VANE**  
Aluminum or Stainless Steel, 28"L  
Plain, Painted, or Gold Leaf

# WEATHERVANES

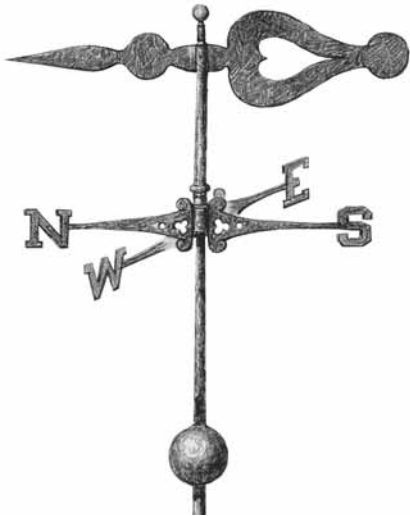

**NO. 3815**  
**"CLOCK HAND" VANE**  
 Aluminum or Stainless Steel, 36"L  
 Plain, Painted, or Gold Leaf

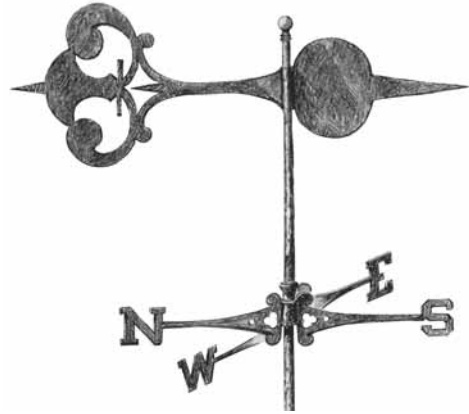

**NO. 3816**  
**"CLOCK HAND" VANE**  
 Aluminum or Stainless Steel, 36"L  
 Plain, Painted, or Gold Leaf

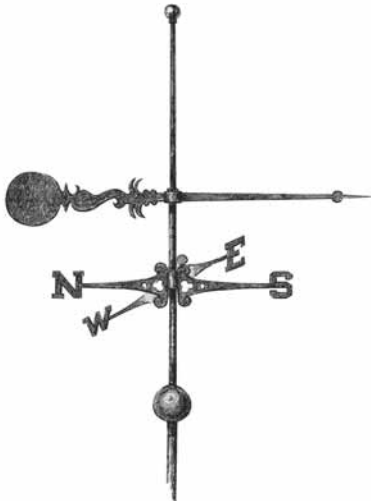

**NO. 3817** **CLOCK HAND VANE**  
 Aluminum or Stainless Steel, 54"L  
 Plain, Painted, or Gold Leaf

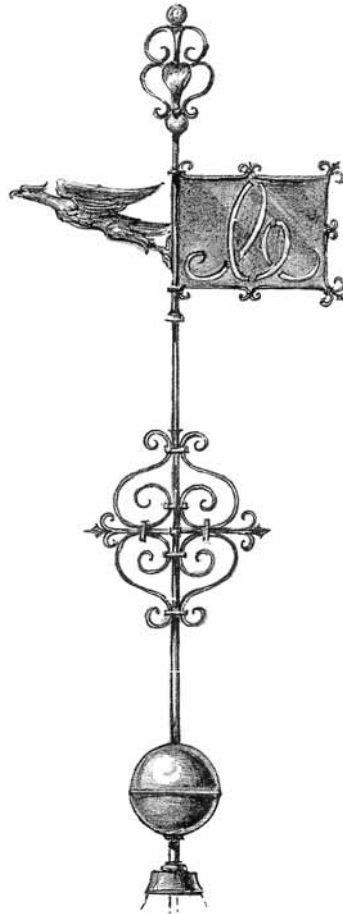

**NO. 3871**  
**WILLIAMSBURG VANE**  
 Aluminum or Copper  
 Plain, Painted, Gold Leaf or Verde Patina

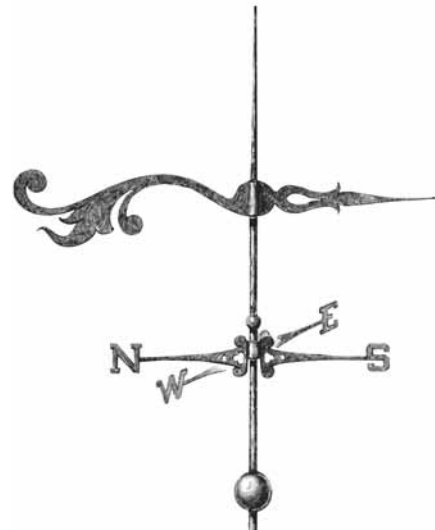

**NO. 3819** **CLOCK HAND VANE**  
 Aluminum or Stainless Steel, 48"L  
 Plain, Painted, or Gold Leaf

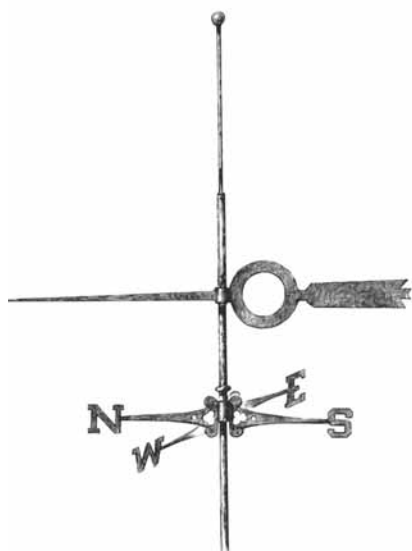

**NO. 3820** **LONG CLOCK HAND VANE**  
 Aluminum or Stainless Steel, 54"L  
 Plain, Painted, or Gold Leaf

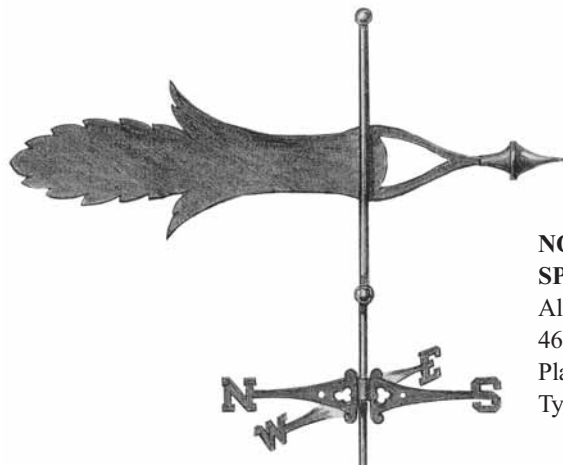

**NO. 3892** **CHURCH SPIRE VANE**  
 Aluminum or Stainless Steel, 46" L  
 Plain, Painted, or Gold Leaf  
 Typical church spire vane.



**NO. 3824 INDIAN VANE**  
Copper, 48"H  
Plain, Gold Leaf or Verde Patina



**NO. 3822 PRIMITIVE INDIAN VANE**  
Copper, 36"H  
Plain, Gold Leaf or Verde Patina



**NO. 3823 PRIMITIVE INDIAN VANE**  
Copper, 48"H  
Plain, Gold Leaf or Verde Patina



**NO. 3824A INDIAN VANE**  
Copper, 48"H  
Plain, Gold Leaf, or Verde Patina



**NO. 3841 PRIMITIVE INDIAN VANE**  
Aluminum or Stainless Steel  
48"High x 30" L  
Plain, Painted, or Gold Leaf

# WEATHERVANES

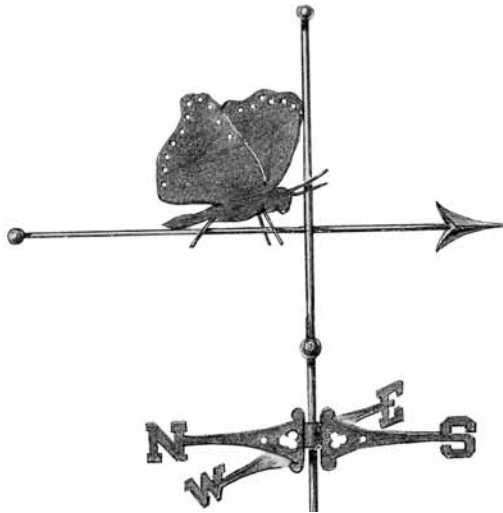

**NO. 3994 BUTTERFLY VANE**  
 Aluminum or Stainless Steel, 36" L  
 "BUTTERFLY" 12" x 14"  
 Plain, Painted, or Gold Leaf

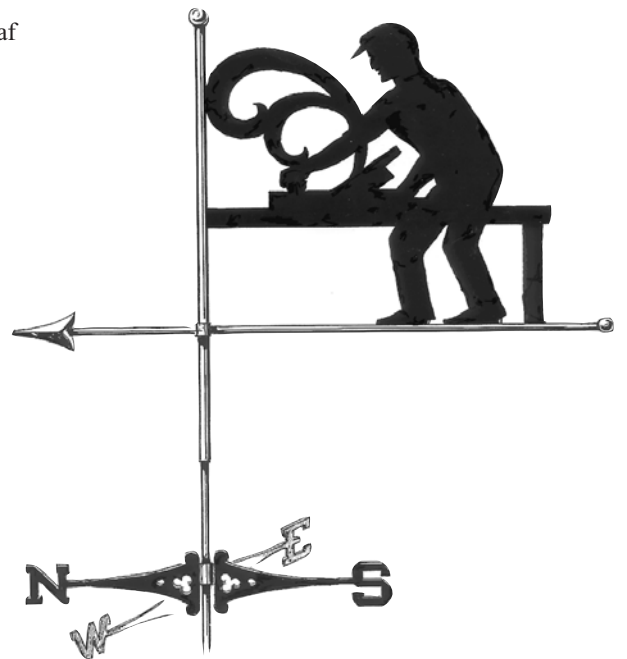

**NO. 3876 CARPENTER WITH PLANE VANE**  
 Aluminum or Stainless Steel, 40" L  
 Plain, Painted, or Gold Leaf



**NO. 3890 EAGLE VANE**  
 Aluminum or Stainless Steel, 36" L  
 Plain, Painted, or Gold Leaf

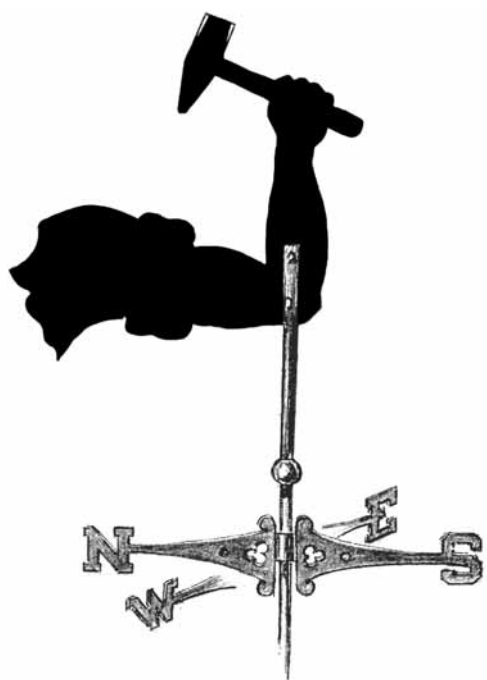

**NO. 3888 ARM & HAMMER VANE**  
 Aluminum or Stainless Steel, 34" L  
 Plain, Painted, or Gold Leaf

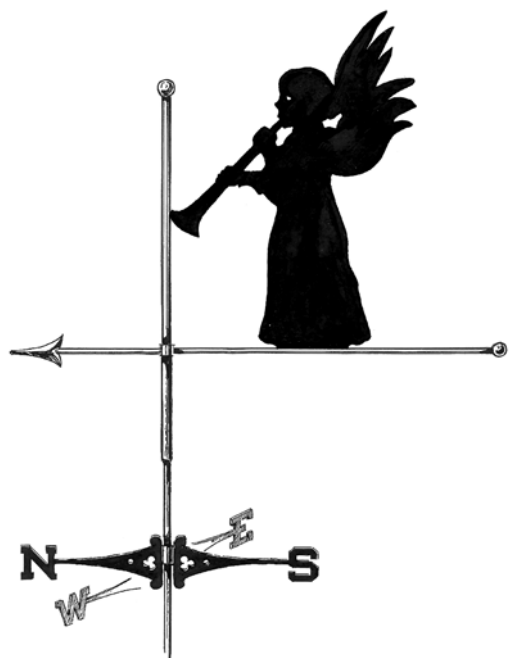

**NO. 3879 ANGEL WITH TRUMPET VANE**  
 Aluminum or Stainless Steel, 30" L  
 Plain, Painted, or Gold Leaf



**NO. 1535 DEER VANE**  
Copper, 31"L  
Plain, Gold Leaf or Verde Patina  
Full bodied 19th century reproduction.



**NO. 3840 BUCK DEER VANE**  
Copper, 42"L  
Plain, Gold Leaf or Verde Patina

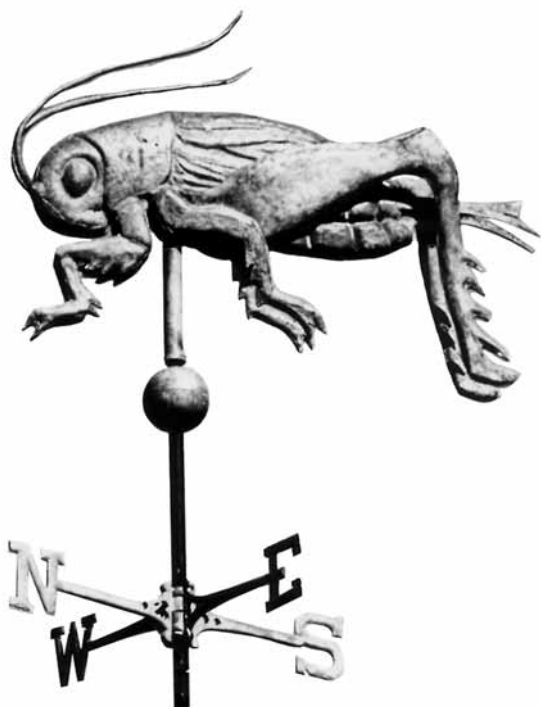

**NO. 3906 CRICKET VANE**  
Copper, 32" L  
Plain, Gold Leaf or Verde Patina

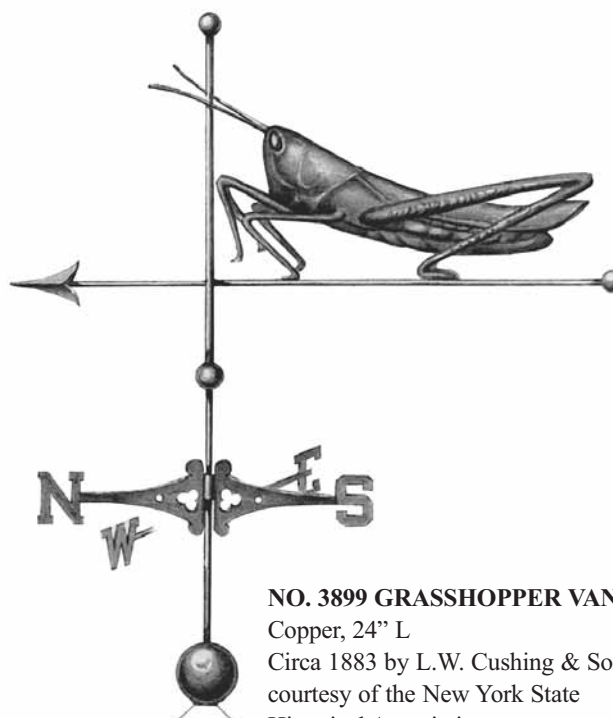

**NO. 3899 GRASSHOPPER VANE**  
Copper, 24" L  
Circa 1883 by L.W. Cushing & Son,  
courtesy of the New York State  
Historical Association.  
Plain, Gold Leaf or Verde Patina

**NOTE:**  
VERDE PATINA  
IS AVAILABLE  
FOR  
COPPER VANES  
ONLY.

**NO. 3865 GRASSHOPPER VANE**  
Copper, 32" L  
Full relief, boldly executed by  
Sculptor Joseph Boulton.  
Plain, Gold Leaf or Verde Patina

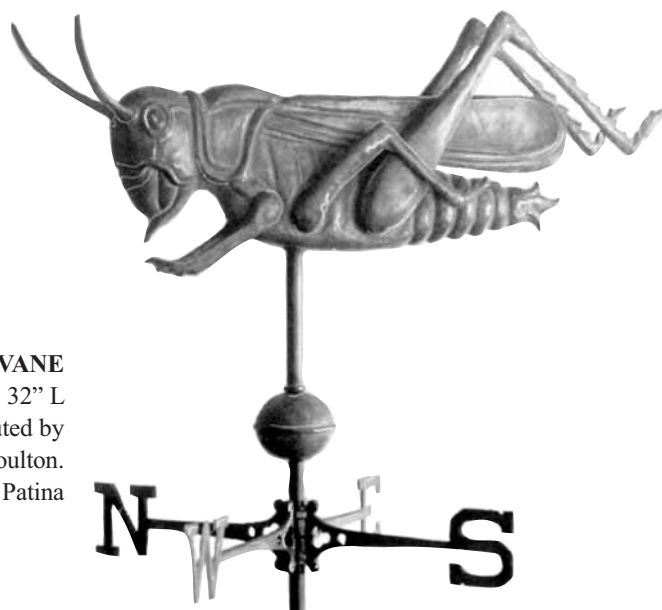

# WEATHERVANES

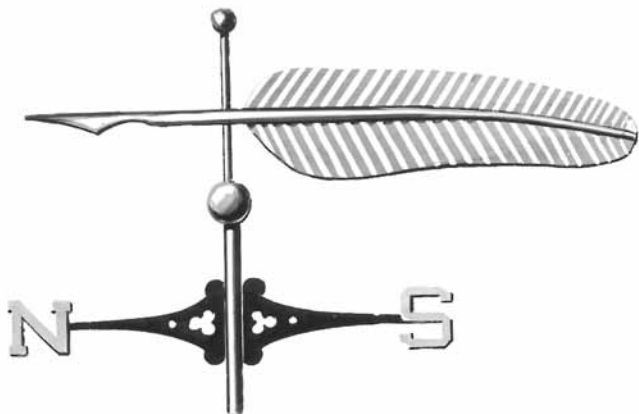

**NO. 1543 QUILL VANE**  
Copper  
24" and 36" L  
Plain, Gold Leaf or Verde Patina

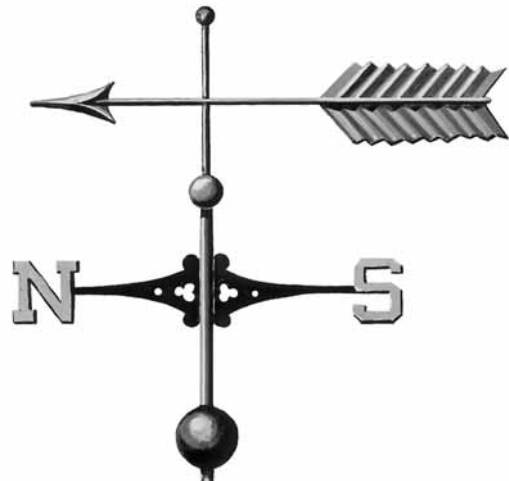

**NO. 2533 ARROW VANE**  
Copper  
18", 20", 24", 42", 48", 60", 72" L  
Plain, Gold Leaf or Verde Patina

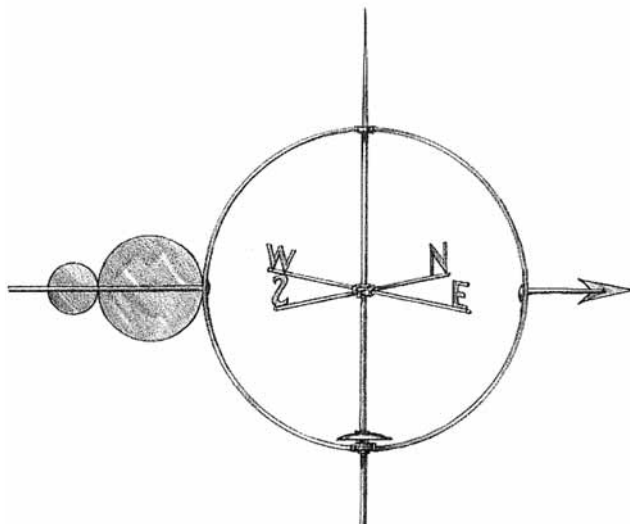

**NO. 2534 RING VANE**  
Stainless Steel, 34" L  
Ring diameter 15"  
Plain, Painted, or Gold Leaf

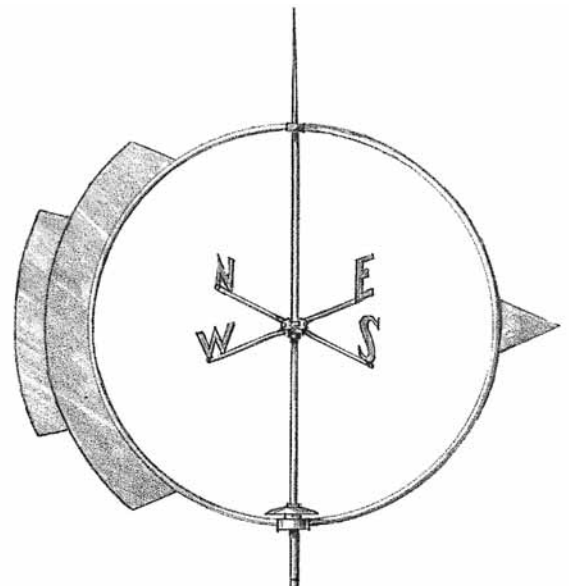

**NO. 2535 RING VANE**  
Stainless Steel, 23" L  
Ring diameter 15"  
Plain, Painted, or Gold Leaf

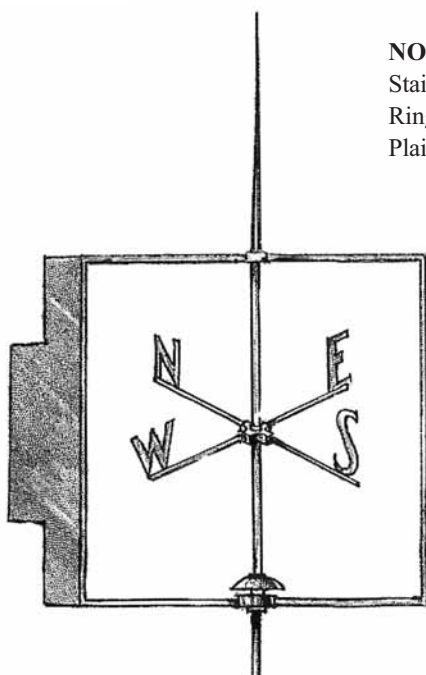

**NO. 2542 BOX KITE VANE**  
Stainless Steel, 22" L  
Plain, Painted, or Gold Leaf

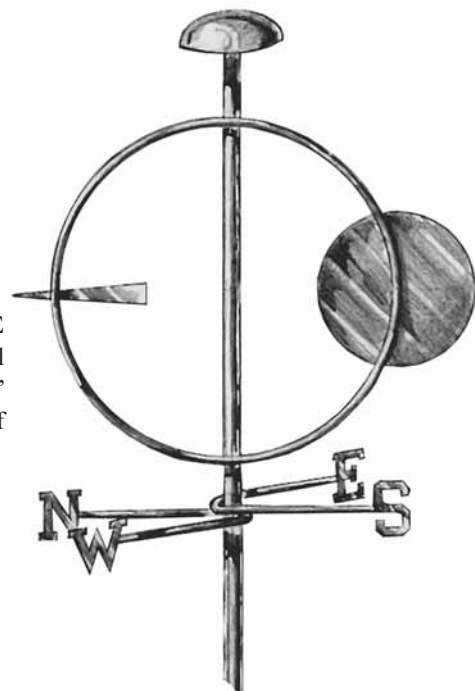

**NO. 4530 RING VANE**  
Stainless Steel, 18" Overall  
Ring diameter 15"  
Plain, Painted, or Gold Leaf



**NO. 4995 LOGO VANE**  
Aluminum, Copper or Stainless Steel  
36" H

Plain, Painted, Gold Leaf or Verde Patina  
As an expression of corporate identity, an excellent opportunity exists to translate a logo or corporate symbol to the weathervane medium. It provides an attractive, readily recognizable enhancement to any structure. The illustrated is for the Rand-McNally Company.

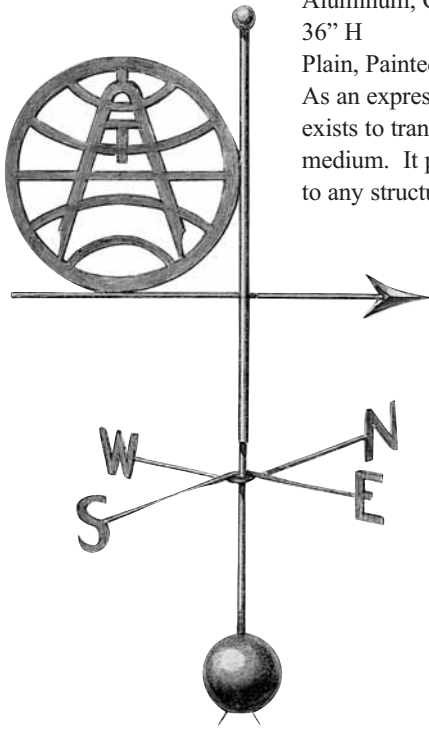

NOTE:  
VERDE PATINA  
IS AVAILABLE  
FOR  
COPPER VANES  
ONLY.

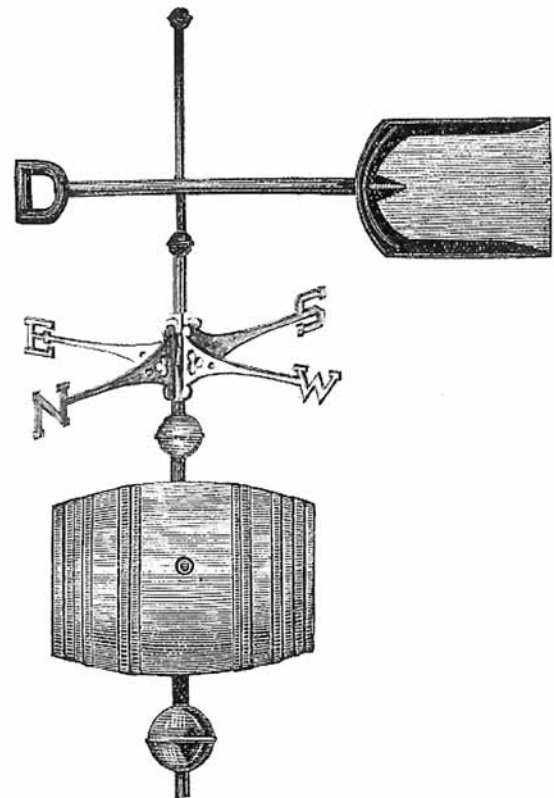

**NO. 3859 WESTERVELT BREWER VANE**  
Copper, 40" L  
Plain, Gold Leaf or Verde Patina  
Made for a brewer with malt shovel and barrel.

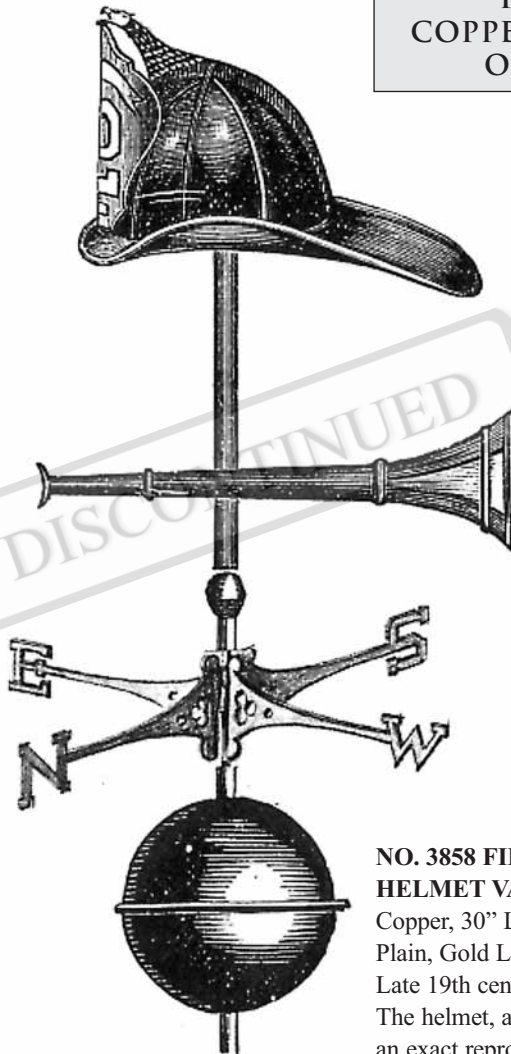

**NO. 3858 FIREMAN HELMET VANE**  
Copper, 30" L  
Plain, Gold Leaf or Verde Patina  
Late 19th century by Westervelt. The helmet, as is the trumpet, is an exact reproduction of those in use during the period. This is entirely made of copper and is fully decorated.

**NO. 3900 FIREMAN VANE**  
Aluminum, Copper or Stainless Steel  
48" overall  
Plain, Painted, Gold Leaf or Verde Patina  
Famous Fireman WeatherVane as made by the J. L. Mott Iron Works many years ago.

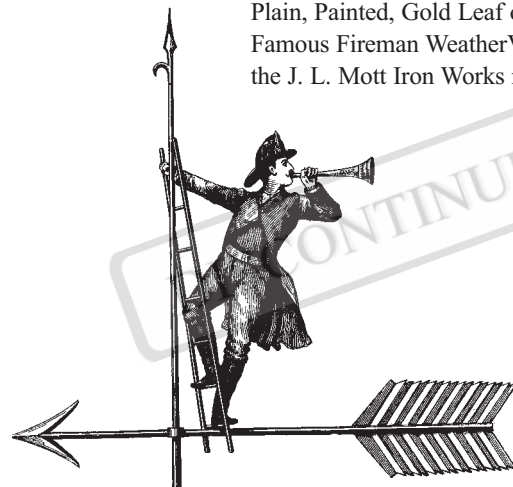

# NEW YORK CITY PARKS

The weathervanes shown on this page were all specified and made for the City of New York Department of Parks, for the use on the comfort stations in the various parks. All are extremely rugged and of stainless steel construction.

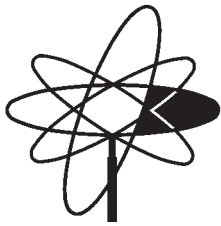

No.7001 Atom

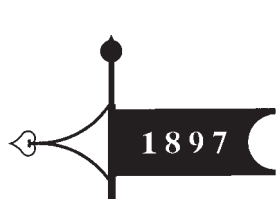

No.7002 Banner

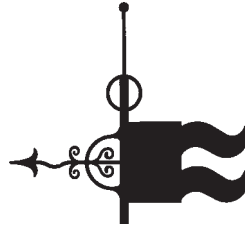

No.7003 Banner



No.7004 Batter



No.7005 Bee



No.7006 Birds



No.7007 Butterfly



No.7008  
Carousel Horse



No.7009 Cat



No.7010  
Cavalry Charge

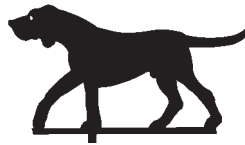

No.7011 Dog



No.7012 Dolphin



No.7013  
Eagle with Banner



No.7014 Fish



No.7015  
Fox and Geese



No.7016 Gargoyle

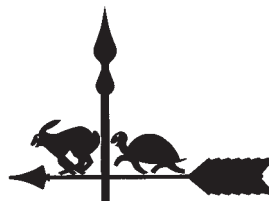

No.7017  
Hare and Tortoise



No.7018 Hawk

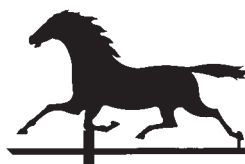

No.7019 Horse



No.7020 Horse



No.7021 Lion

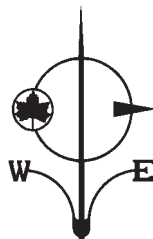

No.7022  
Sycamore Leaf



No.7023  
New York State



No.7024 Rabbit



No.7025  
School of Fish



No.7026  
Sea Captain



No.7027 Sheep



No.7028 Squirrel





19th Century English Weathervanes

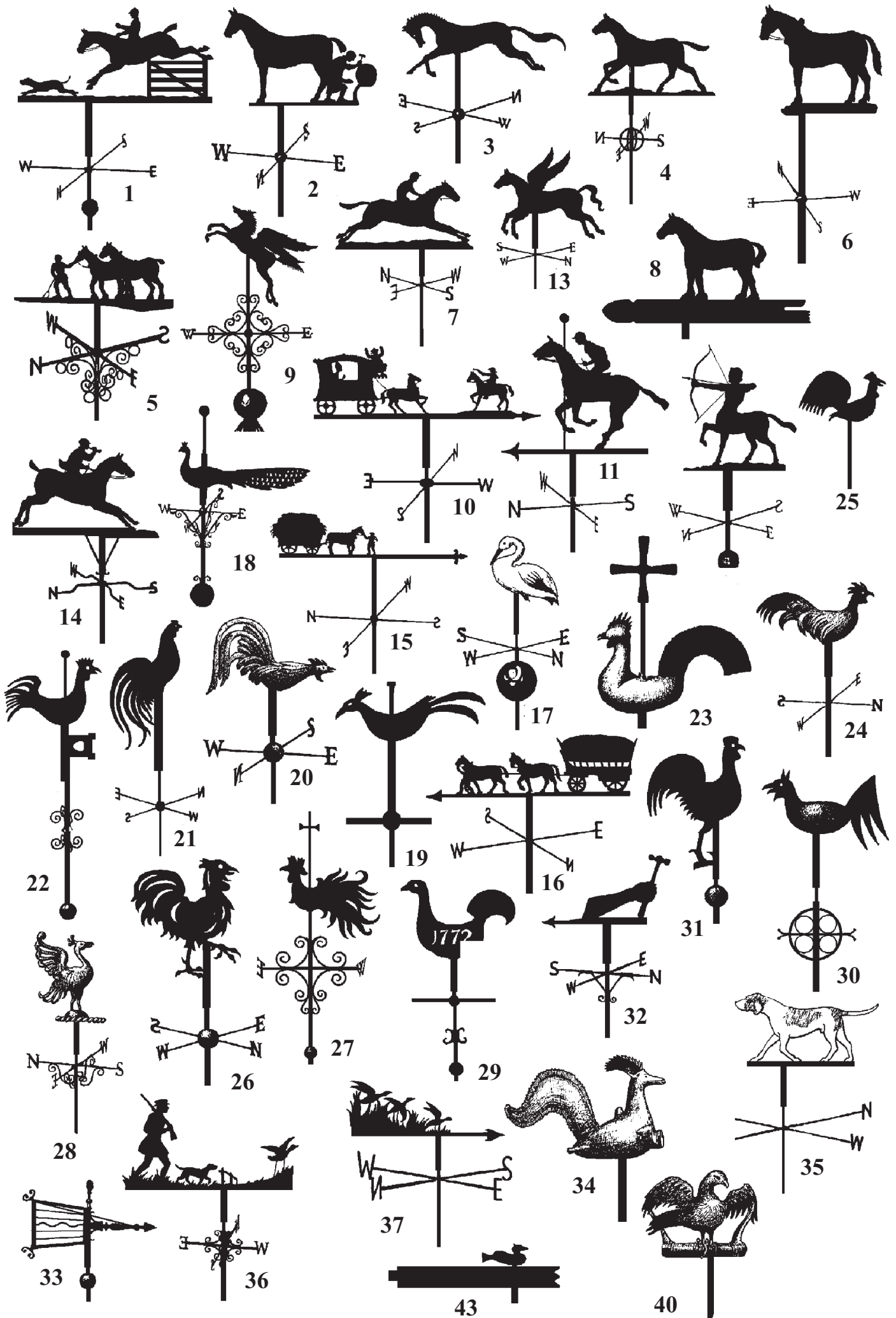

19th Century English Weathervanes

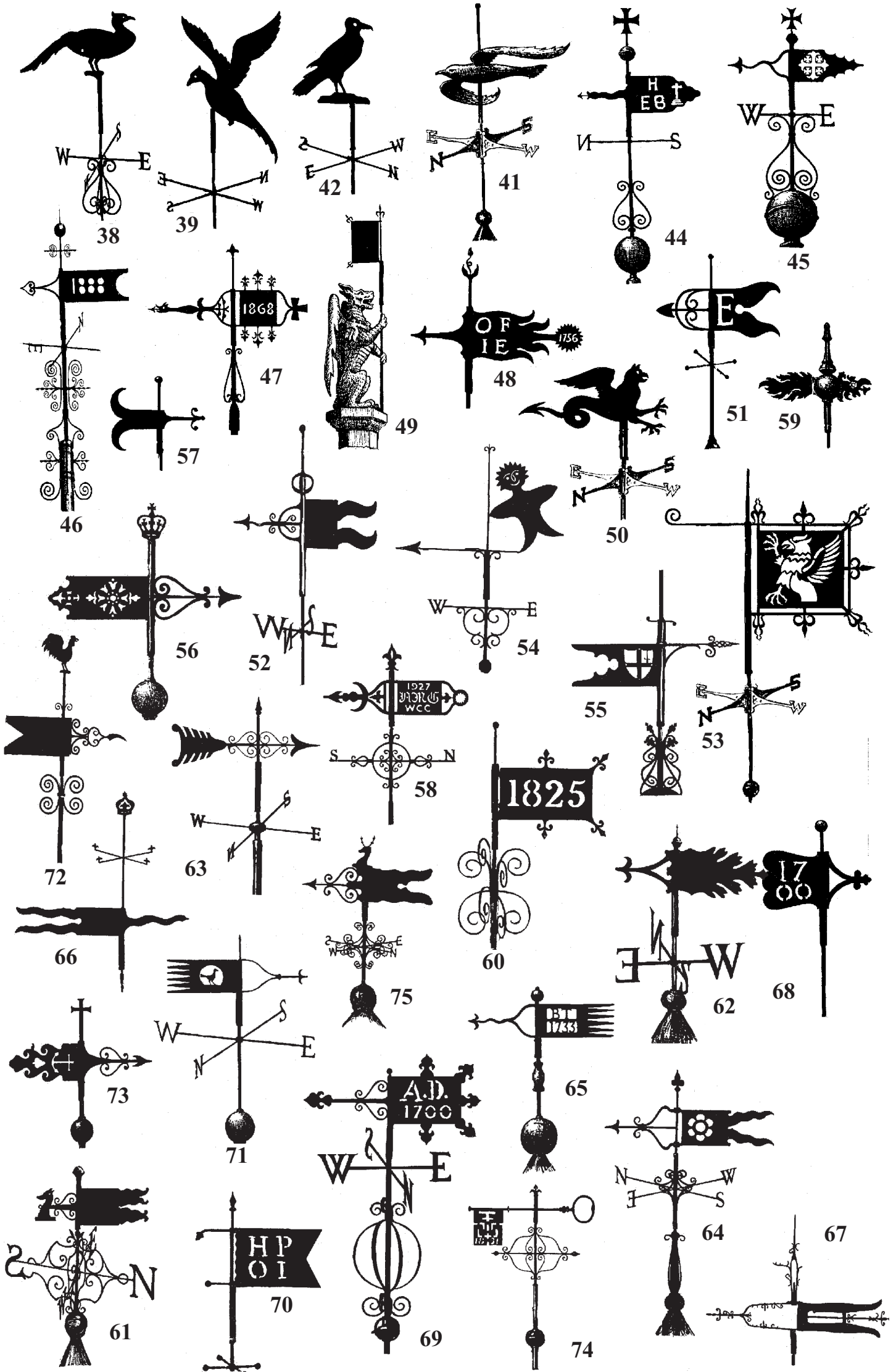



19th Century English Weathervanes

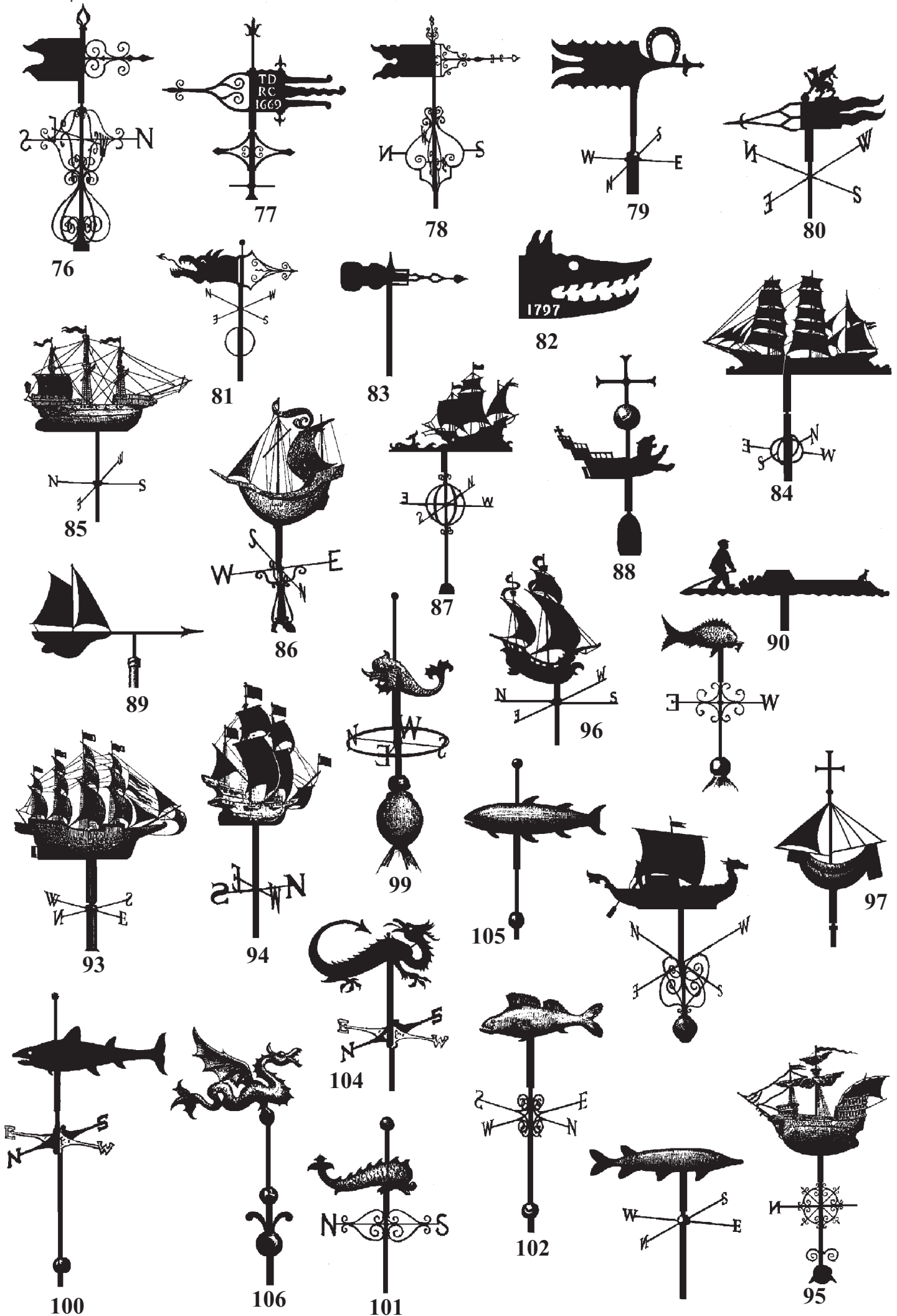

## 19th Century English Weathervanes

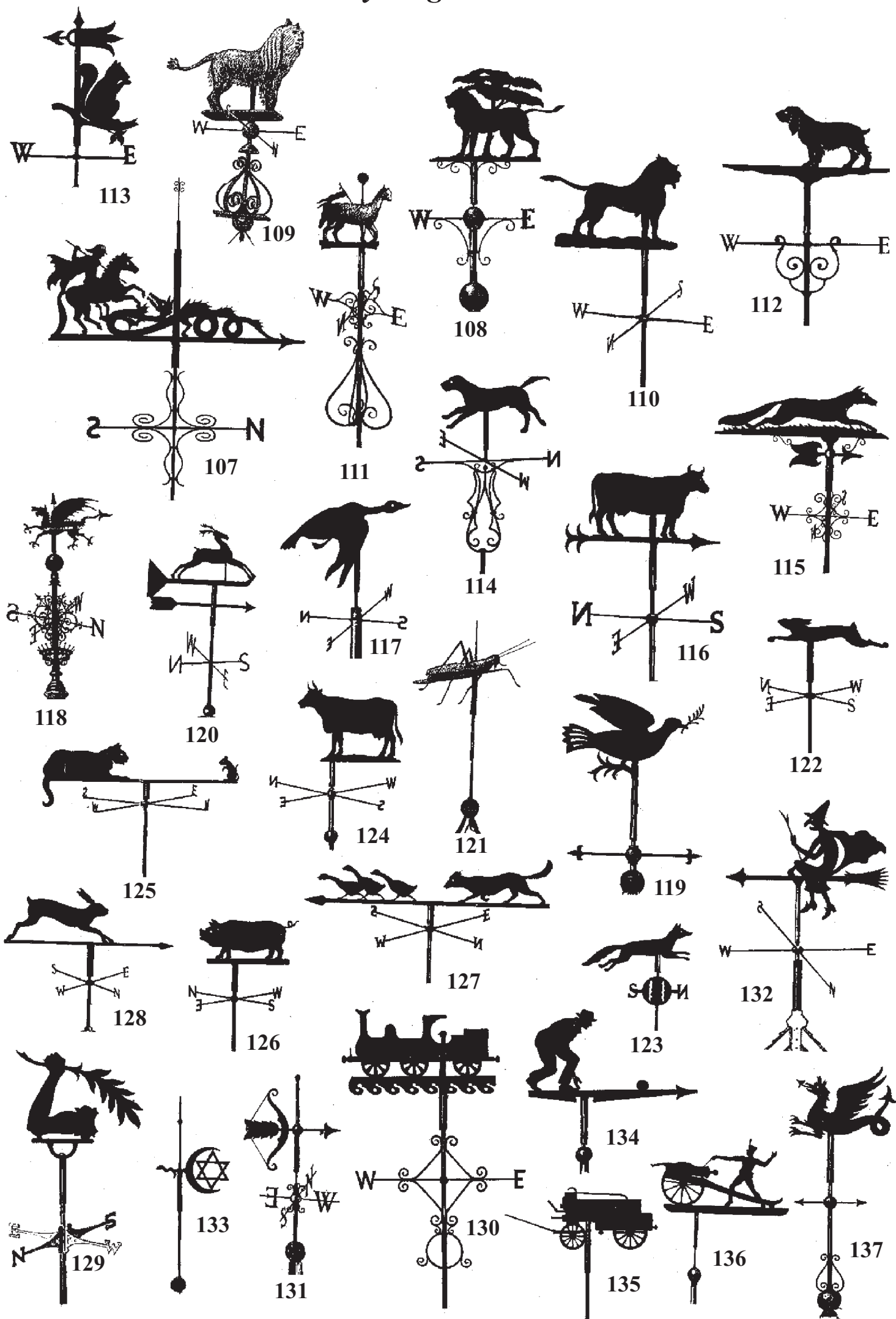



Late 19th, Early 20th Century

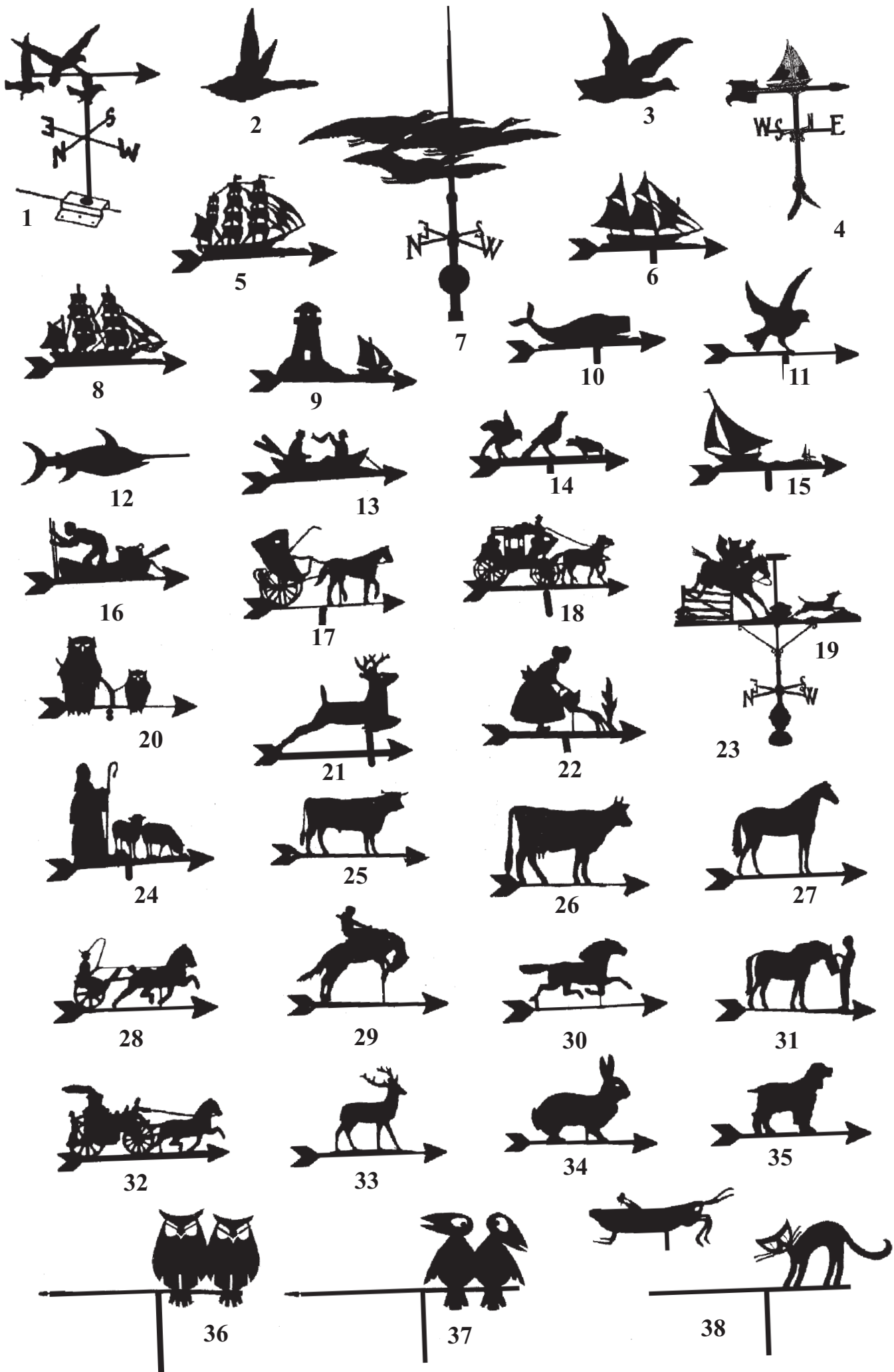

# WEATHERVANES

## Late 19th, Early 20th Century Weathervanes



