



Sundials & Directional Markers



The use of sundials dates back to the dawn of time. The exact origin is unclear except to the extent of archeological research. Literary evidence seems to suggest that there were few, if any, sundials marking the seasons and hours in Greece before the third century, B.C. There is some historical evidence which shows that the origins of the seasonal hours are more likely to be found in the ancient Egyptian (1800 - 1200 B.C.) practice of reckoning nighttime during the year according to the rising of decans. Before the invention of the clock, every town had one or more sundials. They became so well developed that they were both accurate timepieces, as well as important town ornaments.

In the beginning, and even until recently, sundials were made largely of blocks of stone by masons, many of whom were competent dialers. Others worked under the direction of an architect who laid out the sundial for them. These dials were built directly into the building or took the form of a standing pillar with the sundial on one or more sides. This practice continued into the 19th century.

Sundials of tremendous ornamental value and scientific interest were erected all over the world where there was sufficient scientific advance to support this industry. Those who could afford it had an armillary sundial manufactured. The word armillary means rings, so these sundials were made of a series of rings.

The most ornamental of all sundials is the armillary. Next is the hemispherical sundial which is very much like an armillary sliced in half. The horizontal sundials, which are flat, also must be considered because they are traditional in gardens. Wall sundials have also been in use for centuries and are particularly decorative when they become an integral part of the design of a large facade. However, these sundials are the most difficult to time correctly, as one must have the exact orientation of the wall on which the sundial is to be used. Unless the sundial faces exactly due south, very special layout work must be done to make the sundial tell time. Sundials which have signs of the zodiac relate back to the beginning of the telling of time with the ancients.

Concerning the telling of time by a sundial, even though it may be laid out accurately, it tells time correctly only four times each year; on the equinoxes, March 21 and September 23 and the solstices, June 22 and December 22. However, the lines between the numbers on horizontal sundials, those radiating to the center, will always give time within approximately fifteen minutes as long as the sundial has been placed correctly and the gnomon is at the proper altitude. It is important to remember that sundials tell solar time, not local time or daylight savings time.

Materials used in sundials embrace stone, bronze, lead and wrought iron. For horizontal and vertical sundials lead and bronze have historically been the materials of choice. Today, bronze is the material most widely used. Stone, or cast stone can also be used for a variety of sundials, but is more likely to be used for the pedestal. Wrought iron is generally used in a garden where ivy is planned to grow over it. It often is the material of choice for monumental sized sundials of fairly simple design. Sundials make excellent memorials and are very instructional. They are generally highly ornamental and very graceful instruments.

It would hardly be fair to talk about a sundial without mentioning a word about vandalism. A sundial must be securely fastened in place, preferably with stainless steel or bronze dowels which are part of the sundial. We have seen some of our very best sundials and large armillaries at universities withstand the onslaught of students climbing over them repeatedly.

Sundials can be incorporated into any setting, such as a small plaza in a park. This was accomplished in Bloomfield, New Jersey where a large sundial is encircled with attractive benches. They can be used as a focal point in a garden or in front of an Administration or Fine Arts building at a University.

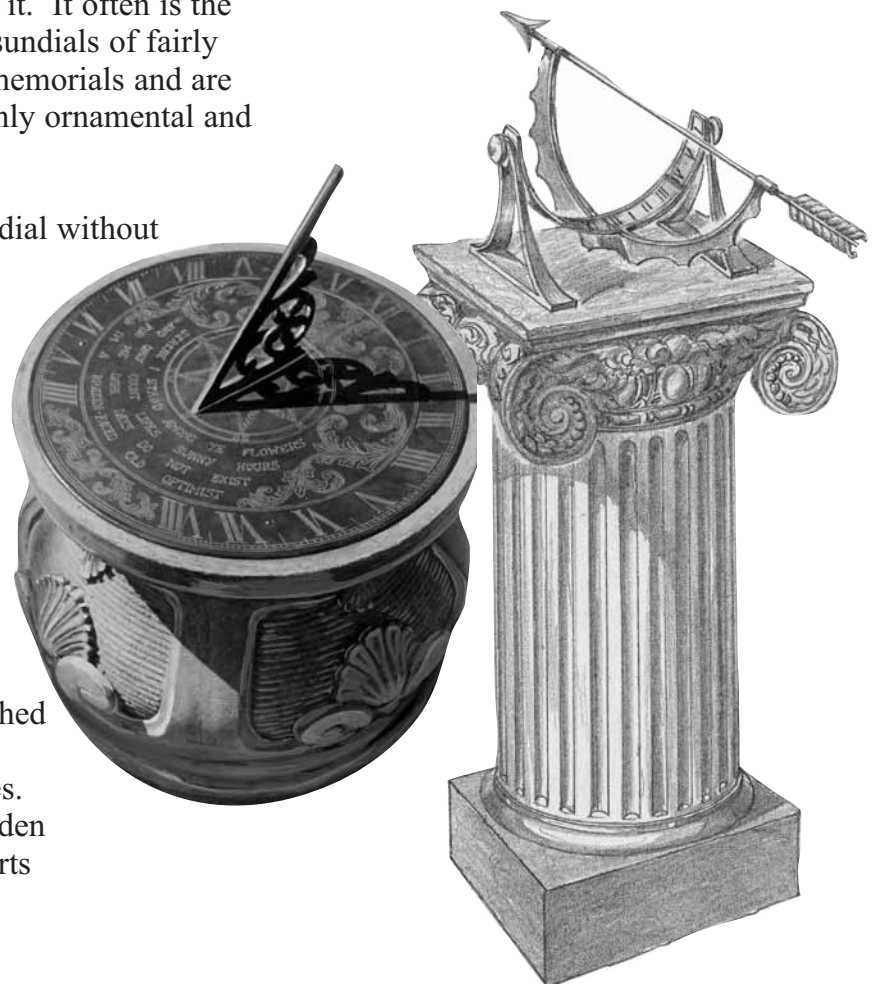



HEAVENLY DAYS

Celestial time telling is just as important to modern man as the ancients, and though the techniques and equipment are more sophisticated, the basics have changed little. The Egyptians, correlating the annual rising of the bright star Sirius with the flooding of the Nile, invented the earliest calendar. Stonehenge was undoubtedly both a calendar dial and a temple for the early Britons, with midsummer sunrise and midwinter sunset related to four of the big stones to mark the summer and winter solstices.

The observation of the sun's height or position in the sky and the corresponding change in the length or position of shadows was the earliest method of telling time. In Babylon and Egypt, as early as 1500 BC, the shadow from a pole or obelisk was noted in relation to permanent markings on the ground that indicated the time of day. By the 14th century AD, the pocket sundial had come into use. Many of these were presented as gifts to royalty or other notables, and displayed a high degree of craftsmanship.

Throughout the Mediterranean area, the system of "temporal" hours, with the day divided into 12 equal parts and the night into 12 equal parts (that differed in duration according to the season) persisted until at least the 14th century, and in Japan it continued until 1873 when Western influences became dominant. While this is satisfactory in equatorial regions where the length of daylight varies by only a few hours year-round, it becomes quite confusing in say, London, where daylight varies from 7 3/4 hours in December to 16 1/2 hours in June.

Although the first public striking clocks were set up in Milan in 1335, sundials were still widely used until early in the 19th century, and continued in general use for setting clocks and watches until the telegraph came into use to send out instantaneous time signals on a nationwide basis. In the early days some watches had sundials mounted inside their cases, should the watch stop functioning.

Sundials tell the time by the passage of the sun over the local meridian, thereby making even local time vary considerably. It was not until 1884 that a worldwide standard time system was adopted. Through this international agreement, the U.S. railroads no longer found it necessary to cope with the difficulty of dealing with fifty different time systems that each railroad had depended on. A traveler from Maine to California might have to change his watch twenty times during the journey, and Pittsburgh alone had six time standards. For a short while railway and local time were used concurrently, but gradually the use of standard time became widely accepted, with a uniform time observed within each of the 24 time zones, measured 15° apart, starting from Greenwich, long the navigator's standard. Within each zone, standard time prevails, and each zone differs from the next by a whole hour.

A sundial, like a sextant, or surveyor's transit, is an instrument for measuring angles. It measures either the altitude of the sun above the horizon or the direction of the sun with relation to a north-south line at the point of observation. The accuracy of the instrument is dependent on precision in manufacture and careful orientation with respect to the horizontal and north-south line. To tell the correct time, one must know where north is, or if one knows the correct time, he may discover his north bearing through the use of a sundial. During World War II, this was put to practical use when large vehicle convoys were crossing the desert wastes of North Africa in pursuit of Rommel. The constant shifting of the steel vehicles made the magnetic compass useless, but since the correct time was readily available by watch or radio, it was possible to ascertain the direction of north by orienting a pocket sundial to the correct time.

Such pocket sundials, or slightly larger ones, are still used. One type of pocket sundial, sold for hikers and campers, has a compass set on the surface with the face, and a table in the lid giving all the variables that must be considered in ascertaining the correct time. Corrections must be made for latitude, longitude and time of year, to say nothing of remembering daylight saving time. Nevertheless, such small sundials can give the correct time within a few minutes. Most large sundials, unless they are custom made for a specific location, are used purely as garden ornaments.

Writing Sundial mottoes was a favorite pastime of dial designers for centuries. As you know, the words of Browning have occupied the face of so many hundreds of sundials that one almost associates a sundial with them: *"Grow old along with me, the best is yet to be."* The almost religious aspects of the mottoes on sundials showed clearly that men were made to think both by the sundial and the motto, such as, *"The Firmament Showeth His Handiwork."*

Other examples of this trend;

"I count none but sunny hours."

*"Let others tell of storms and showers
I'll only count your sunny hours."*

*"United in time, parted in time
to be reunited when time
shall be no more."*

"Thus eternity approacheth."

"Trifle not your time's short."

"Time can do much."

*"A clock the time may wrongly tell
I never if the sun shines well."*

*"I waken with the rising sun
and sleep when his long course is run."*



Example of No. 2500S installed at Miami University in Oxford, Ohio



NO. 2500S ARMILLARY SUNDIAL

Available in three sizes:

48", 60" or 72" diameter

This sundial is made as small as 48" in diameter and as large as 72" in diameter. Decorating the Equatorial ring are beautifully modeled Zodiacs by Gifford Proctor. The Zodiacs are generally Gold leafed. This is a magnificent piece of work, beautifully executed, and finished in verde antique Bronze.

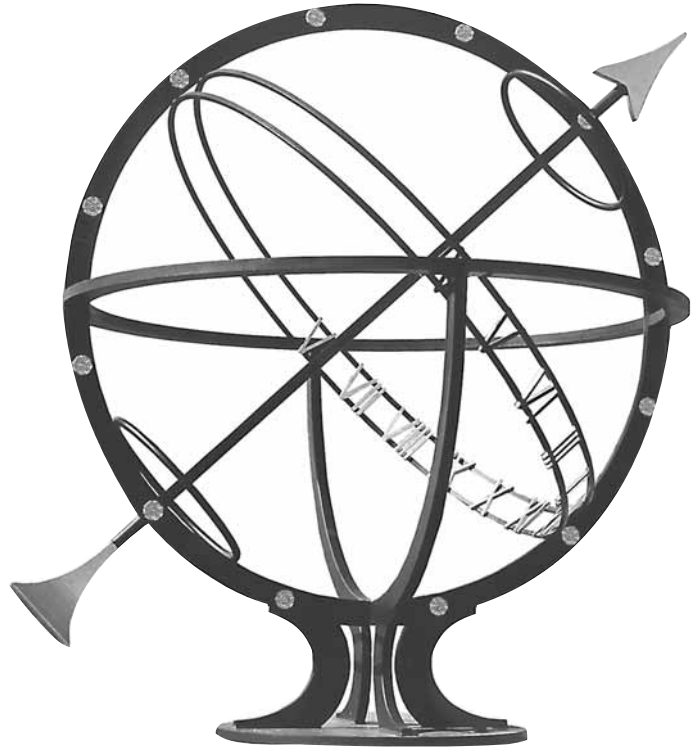

NO. 3543 ARMILLARY SUNDIAL

Available in three sizes:
48", 60" or 72" diameter

Unusual Wrought Iron armillary sundial, extremely strong.
It is garnished with signs of the Zodiac.

NO. 3450A ARMILLARY SUNDIAL

122 1/2" diameter (10 feet, 2 1/2 inches)

The sundial is made only of Wrought Iron with gilded ornament.



NO. 3450B ARMILLARY SUNDIAL

72" diameter

The sundial is made only of Wrought Iron with gilded ornament.

SUNDIALS

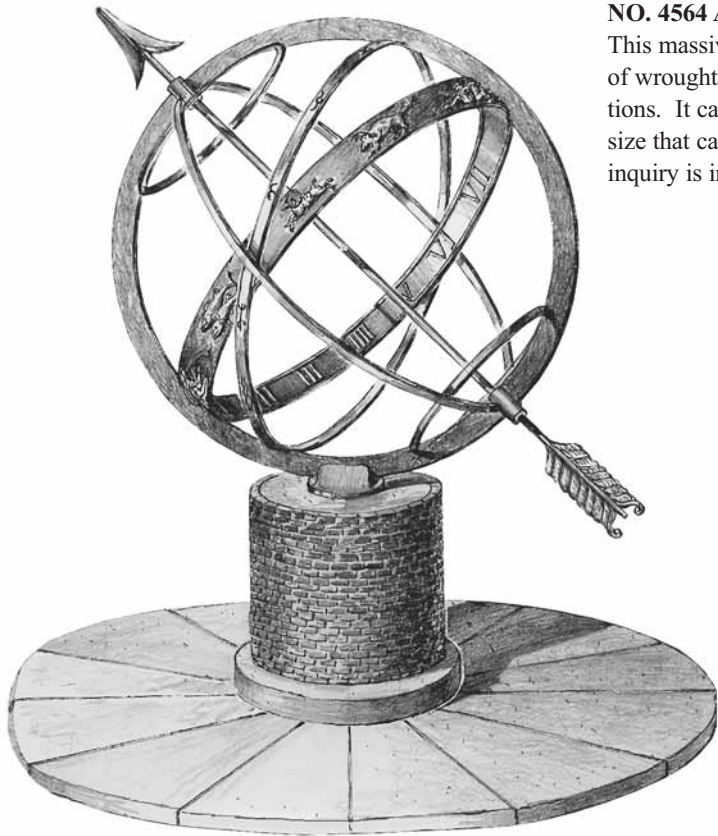

NO. 4564 ARMILLARY SUNDIAL

This massive armillary sundial made of wrought iron is of great proportions. It can be made practically any size that can be transported. Your inquiry is invited.

Bronze sundials can be left plain to weather naturally or they can be patinated. The patina choices are: Statuary Bronze (a brown finish with highlights of Bronze) or a Verde Patina (which is an antique green). Both patinas are expertly applied and will maintain their finish for a long period of time. There is an additional charge for patina.

Elements of Bronze sundials may also be gilded. There is an additional charge for gilding.

NO. 3530 ARMILLARY SUNDIAL

Available in three sizes:
48", 72" or 96" diameter

Bronze armillary sundial, finished in verde antique bronze with water leaf placed in ring. Highly sophisticated and an exceptionally neat design. The Equatorial ring is garnished with signs of the Zodiac and numerals. Cast Stone base is sold separately.



NO. 3511A ZODIAC AND NUMERAL SUNDIAL WITH PEDESTAL



NO. 3511 ZODIAC AND NUMERAL SUNDIAL

Available in 36", 48" or 60" diameters
Bronze and Cast Stone sundial with Bronze Zodiac symbols. This particular sundial was created as a variation of the original No. 2598 (seen on the next page).

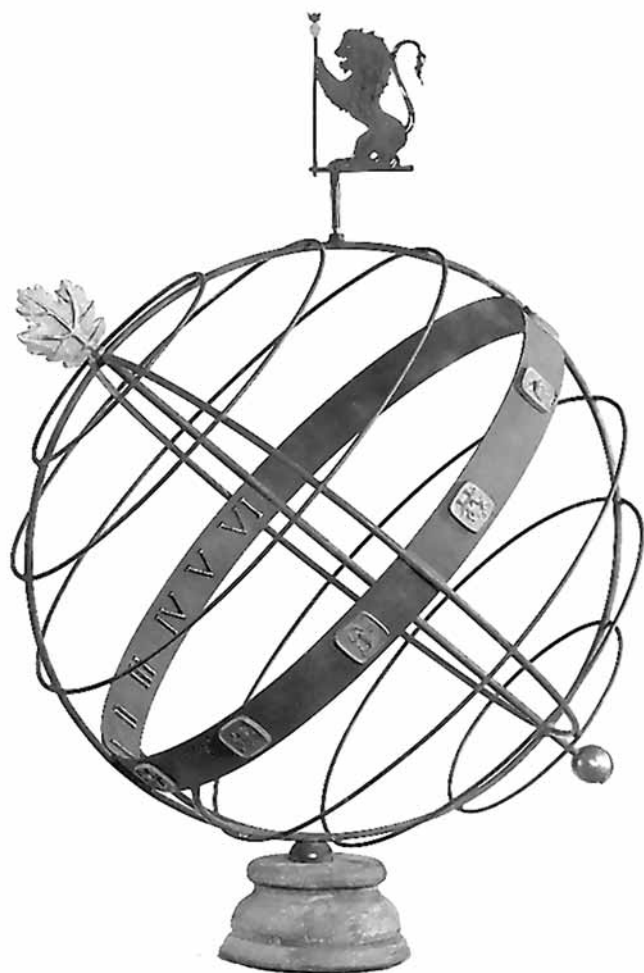

NO. 2313 ARMILLARY SUNDIAL

Available in 36" or 48" diameters
Wrought Iron sundial with Lead Zodiac symbols.
Can be used partly as a topiary frame.

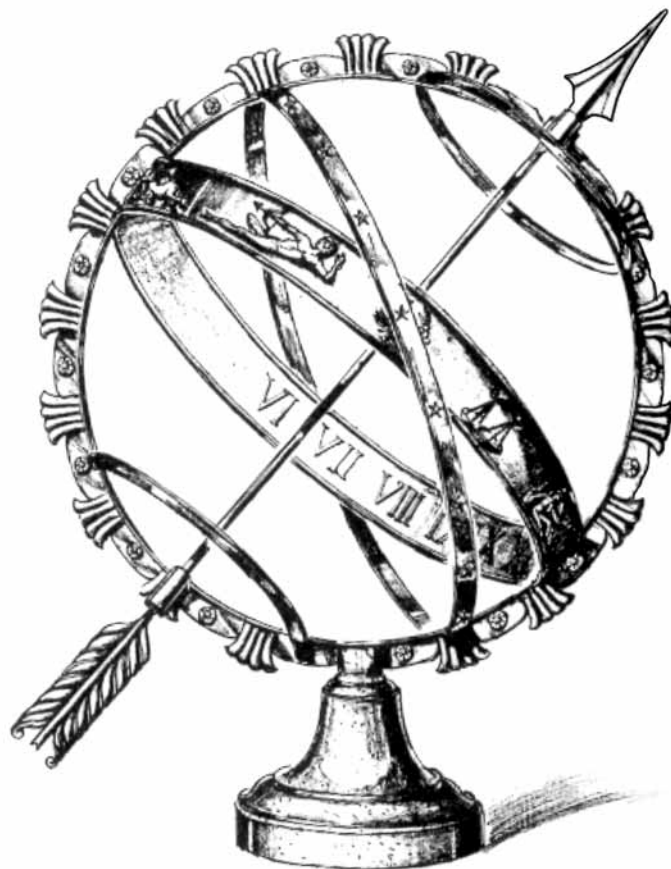

NO. 2598 ARMILLARY SUNDIAL

Available in three sizes: 36", 48", or 60" diameter
All Bronze sundial garnished with signs of the Zodiac,
Roman numerals, and beautifully executed ring with Gold
leaf. It is finished in Bronze patina and mounted on a special
Bronze pedestal. (See No. 3511 as a variation on this design.)

Note: See pedestal pages for a good selection of pedestals to mount sundials. In many cases where the sundial might not fit a particular pedestal you might use an available adaptor.

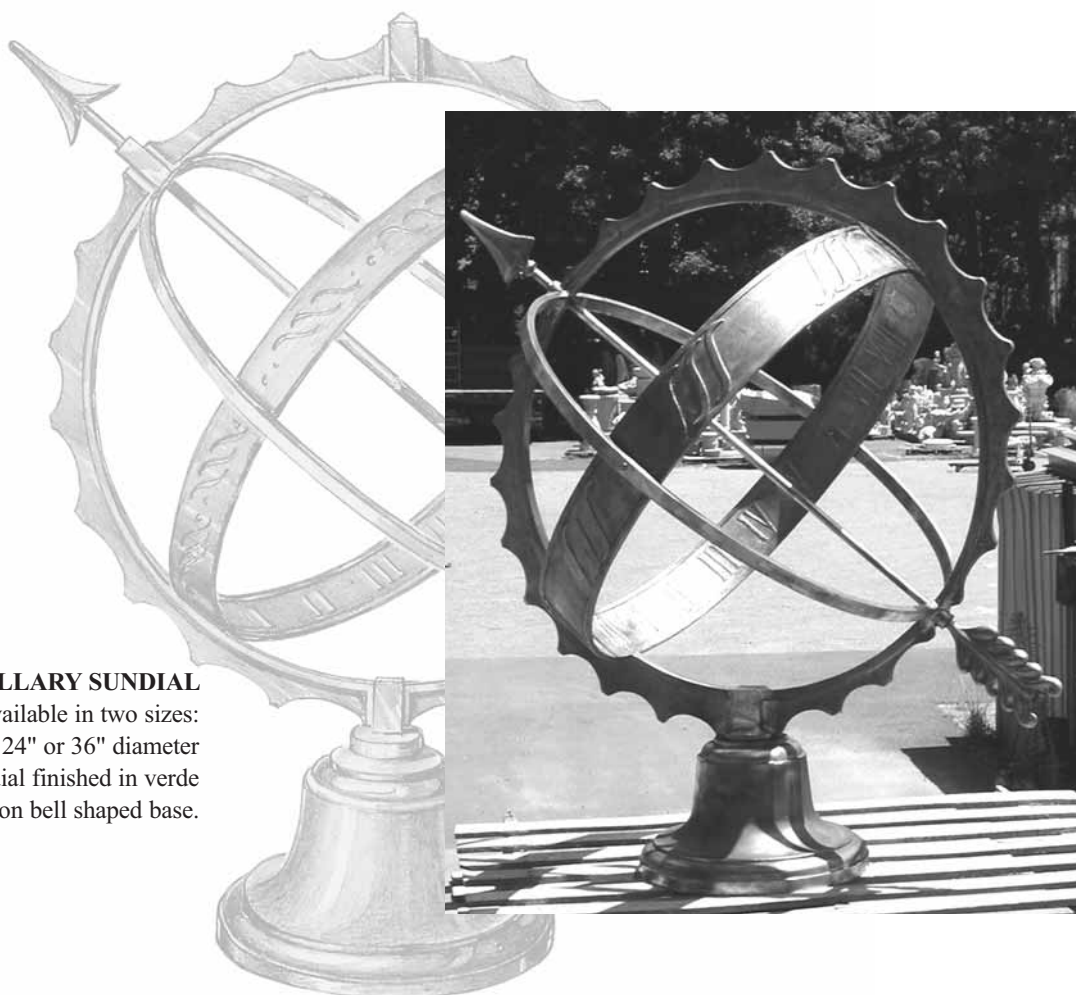

NO. 4563 ARMILLARY SUNDIAL

Available in two sizes:
24" or 36" diameter
Bronze armillary sundial finished in verde
antique mounted on bell shaped base.

SUNDIALS

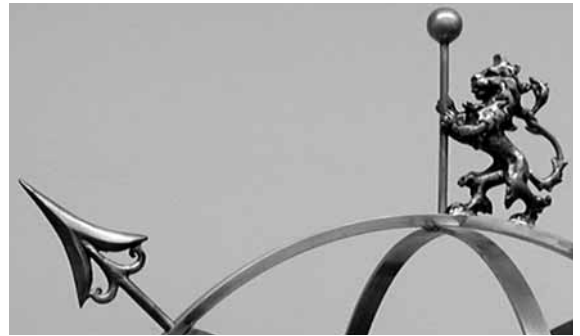

**NO. 4201 ENGLISH DESIGN
BRONZE ARMILLARY SUNDIAL
WITH LION AND ORB**

30" diameter

Choose a cast stone pedestal or we can include a Bronze bell base.
Pedestal is sold separately.



Bronze sundials can be left plain to weather naturally or they can be patinated. The patina choices are: Statuary Bronze (a brown finish with highlights of Bronze) or a Verde Patina (which is an antique green). Both patinas are expertly applied and will maintain their finish for a long period of time. There is an additional charge for patina.

Elements of Bronze sundials may also be gilded. There is an additional charge for gilding.



NO. 3541 ARMILLARY SUNDIAL

30" diameter

Bronze

Choose a cast stone pedestal.
Pedestal is sold separately.

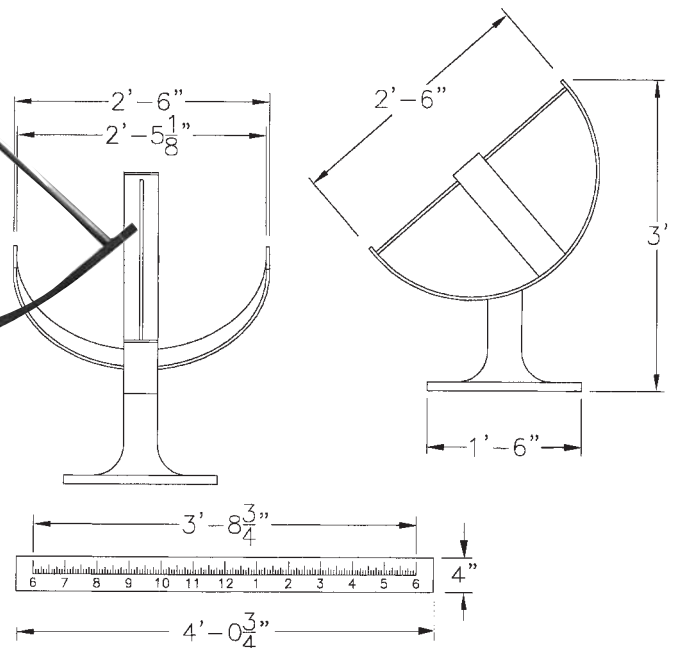



Note: See pedestal pages for a good selection of pedestals to mount sundials. In many cases where the sundial might not fit a particular pedestal you might use an available adaptor.



NO. 1505 ARMILLARY SUNDIAL

Available in three sizes:

- 15" h X 12" diameter 7 3/4" dia base for 15" &
- 25" h X 20" diameter 25" Sundial
- 30" h X 24" diameter 10" base for 30" sundial

All Bronze armillary sundial complete with Zodiac base and equatorial ring, also with the symbols of the Zodiac surrounding it.

NO. 2537 HEMISPHERICAL SUNDIAL

18" h x 16 1/2" diameter
Bronze antique reproduction.



NO. 2538 ARMILLARY SUNDIAL

22" h X 18" diameter
Bronze antique reproduction from Sweden. Armillary type sundial with a heavy coin-like base rising up in the shape of a pyramid which is used to enclose the anchor.



NO. 2539 HEMISPHERICAL SUNDIAL

19 1/2" h X 17" diameter 5 1/2" diameter base
Bronze antique sundial reproduction with snake ornament for Meridian. The snake indicates healing.

SUNDIALS

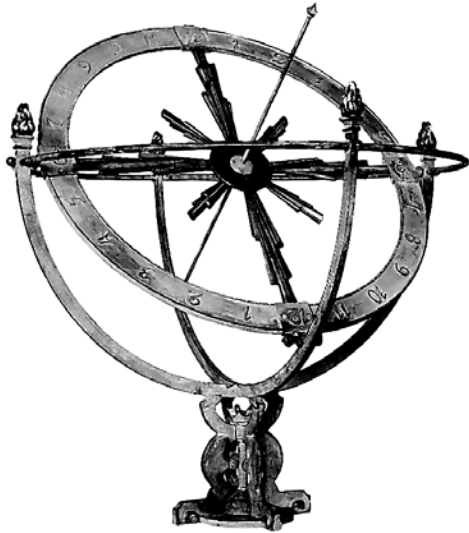

NO. 2540 TRUNNION SUNDIAL

21" X 18" diameter

Antique reproduction Bronze sundial, with four supporting members reaching up and terminating in flames. The base is composed of four Bronze scrolls clustered around a center column which provides for anchoring.

Note: See pedestal pages for a good selection of pedestals to mount sundials. In many cases where the sundial might not fit a particular pedestal you might use an available adaptor.



NO. 2541 HEMISPHERICAL SUNDIAL

25"h X 20" diameter

Antique reproduction Bronze sundial.

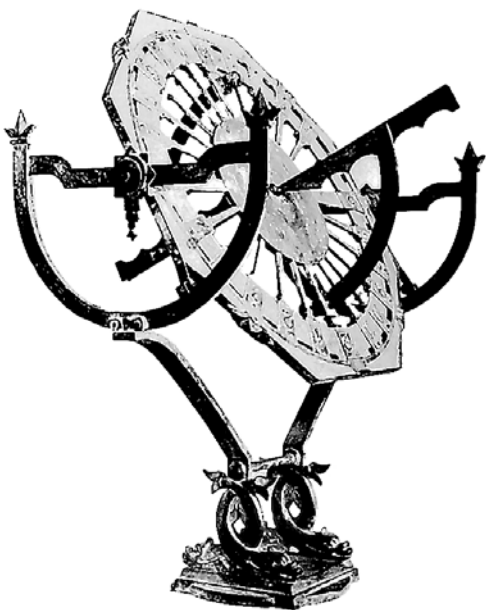

NO. 2543 TRUNNION SUNDIAL

Approx. 24"h

Antique reproduction of an adjustable Swedish trunnion type Bronze sundial of unusual design. The trunnion supports are braced at the bottom by two entwined dolphins. It is nicely executed and beautiful to admire



NO. 2546 ARMILLARY SUNDIAL

20"diameter 8" diameter base

Bronze armillary sundial from a collection brought from France about 1918.



CYCLE OF LIFE SUNDIAL
Bronze
Sculpted by Paul Manship.
Photo taken in
Brookgreen Gardens,
South Carolina.

SUNDIALS



NO. 2599 DANISH SUNDIAL

26" h X 20" diameter

Antique reproduction Bronze sundial from part of a Danish collection. Highly ornamental ring system resting on four Bronze scroll-like feet and supported by a center post which includes the anchor.

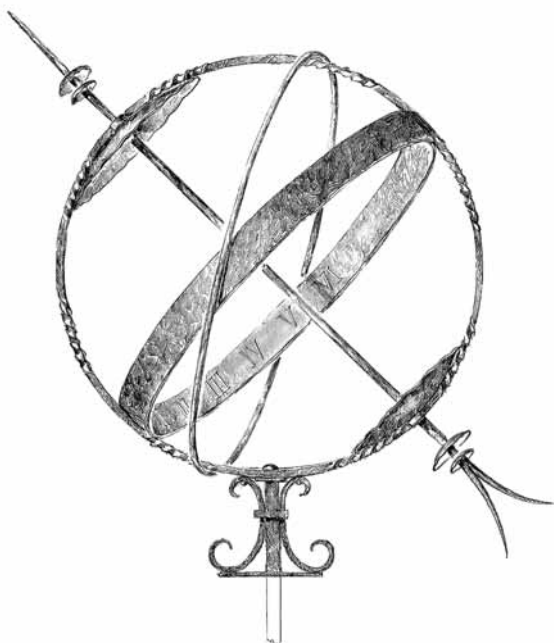

NO. 4236 ARMILLARY SUNDIAL

36" diameter

Beautifully made Wrought Iron sundial. The numerals are made of Lead and the terminals of the arrow seem to have fragmented discs on them.

Note: See pedestal pages for a good selection of pedestals to mount sundials. In many cases where the sundial might not fit a particular pedestal you might use an available adaptor.



NO. 4562 ARMILLARY SUNDIAL

22 1/2" diameter

Gnomon arrowhead to fletching 30" l

Bronze armillary sundial with Bronze base.



NO. 4561 ARMILLARY SUNDIAL

22 1/2" diameter

Gnomon arrowhead to fletching 30" l.

Bronze armillary sundial with Bronze base.



NO. 150 HEMISPHERICAL SUNDIAL

1" from Arrow to Fletching.
Bronze hemispherical sundial
of unusual merit.

**NO. 2601
HEMISPHERICAL
SUNDIAL**

Available in two sizes:
30" or 36" arrowhead
to fletching.
A Bronze hemispherical
sundial of unusual merit.

**NO. 2601A
HEMISPHERICAL
SUNDIAL WITH PEDE-
TAL**

Also available in two sizes:
30" or 36" arrowhead
to fletching.
Shown on pedestal
No. 194, 41" h

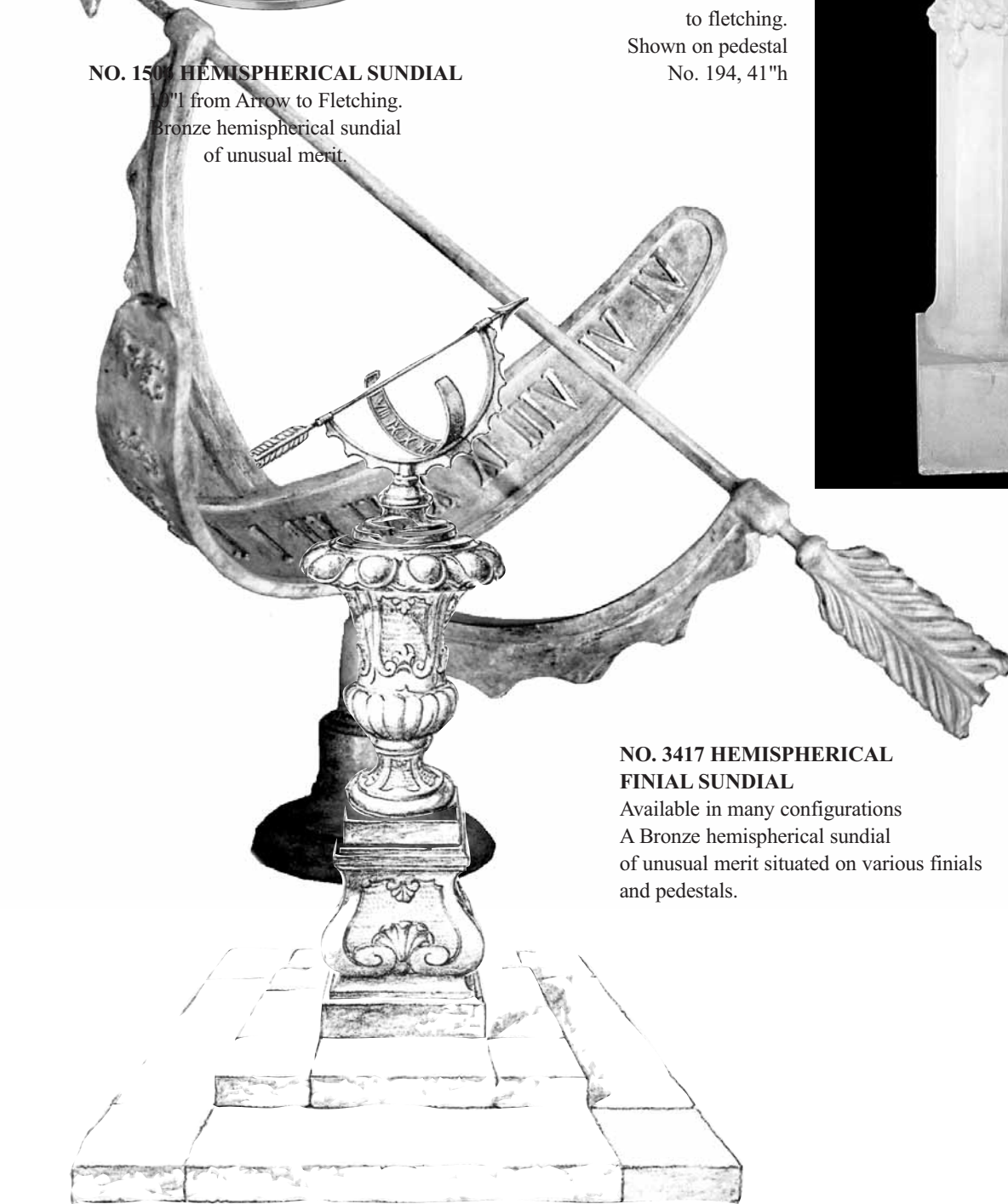

**NO. 3417 HEMISPHERICAL
FINIAL SUNDIAL**

Available in many configurations
A Bronze hemispherical sundial
of unusual merit situated on various finials
and pedestals.

SUNDIALS



NO. 3420 HEMISPHERICAL Sundial

Up to 96" diameter available.
Wrought Iron sundial of large proportions with Iron equatorial band and cast Bronze or cut Stainless Steel numerals. Can be mounted on a suitable sturdy base.

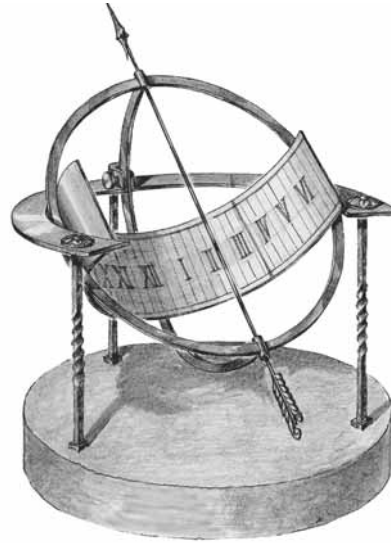

NO. 3421 HEMISPHERICAL Sundial

Available in four sizes:
36", 48", 72", or 96" diameter
This handsome Wrought Iron sundial comes with a Cast Stone base in small sizes or the base is cast in place in the case of larger sizes. While the sundial can be made to be adjustable, it is not recommended. As this is a sketch, its design is not absolute.

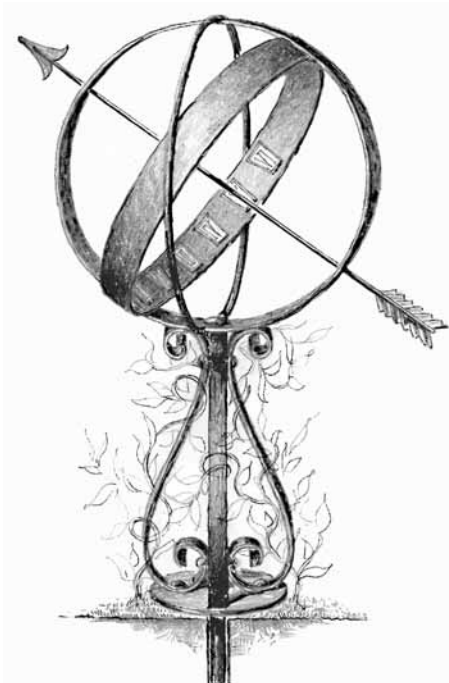

NO. 3424 ARMILLARY Sundial

36" diameter
Wrought Iron armillary frame intended for use as a means of growing ivy from the base up through the entire sundial.



NO. 3443 ARMILLARY Sundial

30" diameter
This sundial is made only of Wrought Iron with Stainless Steel numerals on four scroll-like feet.



NO. 2597 LEAD ATLAS WITH BRONZE ARMILLARY SUNDIAL

Available in two sizes:
36"h or 54"h

Note: See pedestal pages for a good selection of pedestals to mount sundials. In many cases where the sundial might not fit a particular pedestal you might use an available adaptor.



NO 4657 ARMILLARY SUNDIAL

Bronze.
Decorated with the symbols of the Zodiac.



NO. 2085A ATLAS WITH CAST STONE SPHERE SUNDIAL

Cast Stone, 51"h
The figure is 36"h and the sphere adds an additional 15" to the height.

NO. 2085 ATLAS WITH SPHERE
Same as above without sundial.

SUNDIAL ZODIACS

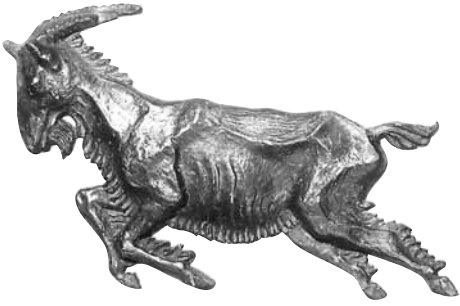

NO. 2335 CAPRICORN



NO. 2335 AQUARIUS

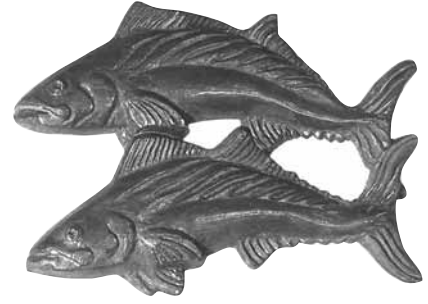

NO. 2335 PISCES



NO. 2335 ARIES



NO. 2335 TAURUS



NO. 2335 GEMINI

NO. 2335 ZODIACS - Available in 3 sizes:
 6" X 12" average, 4" X 7" average, 3" X 5" average.
 The size referred to is the area needed for placement. They have an almost chiseled quality to them having been designed with tremendous care for the sculptural appearance.
 Available in Lead or Bronze. Can be purchased as a set or individually.

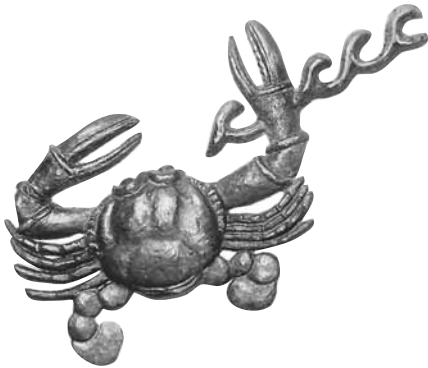

NO. 2335 CANCER



NO. 2335 LEO



NO. 2335 VIRGO



NO. 2335 LIBRA

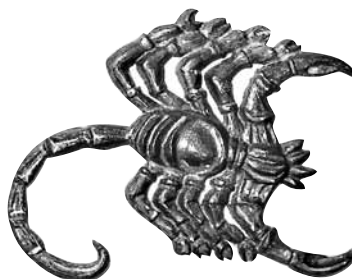

NO. 2335 SCORPIO



NO. 2335 SAGITTARIUS



The Zodiac table at the right shows the dates of each sign. The sphere was divided by the ancients into twelve segments of thirty degrees each, thus the twelve signs of the Zodiac. The signs derive their names from the constellations with which they coincided two millenniums ago.

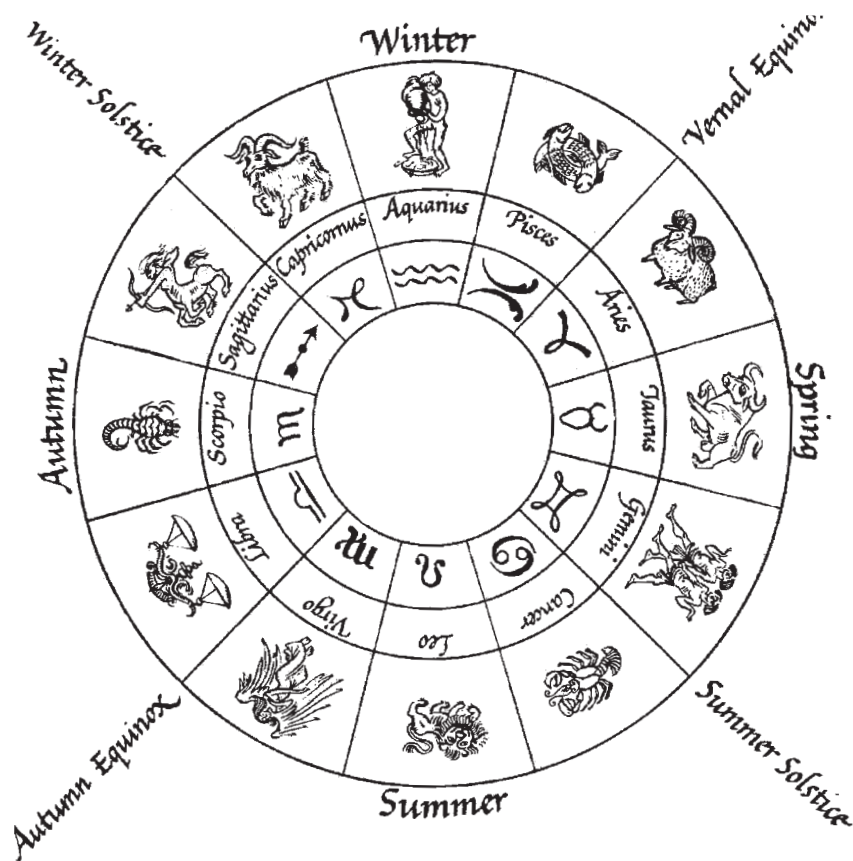
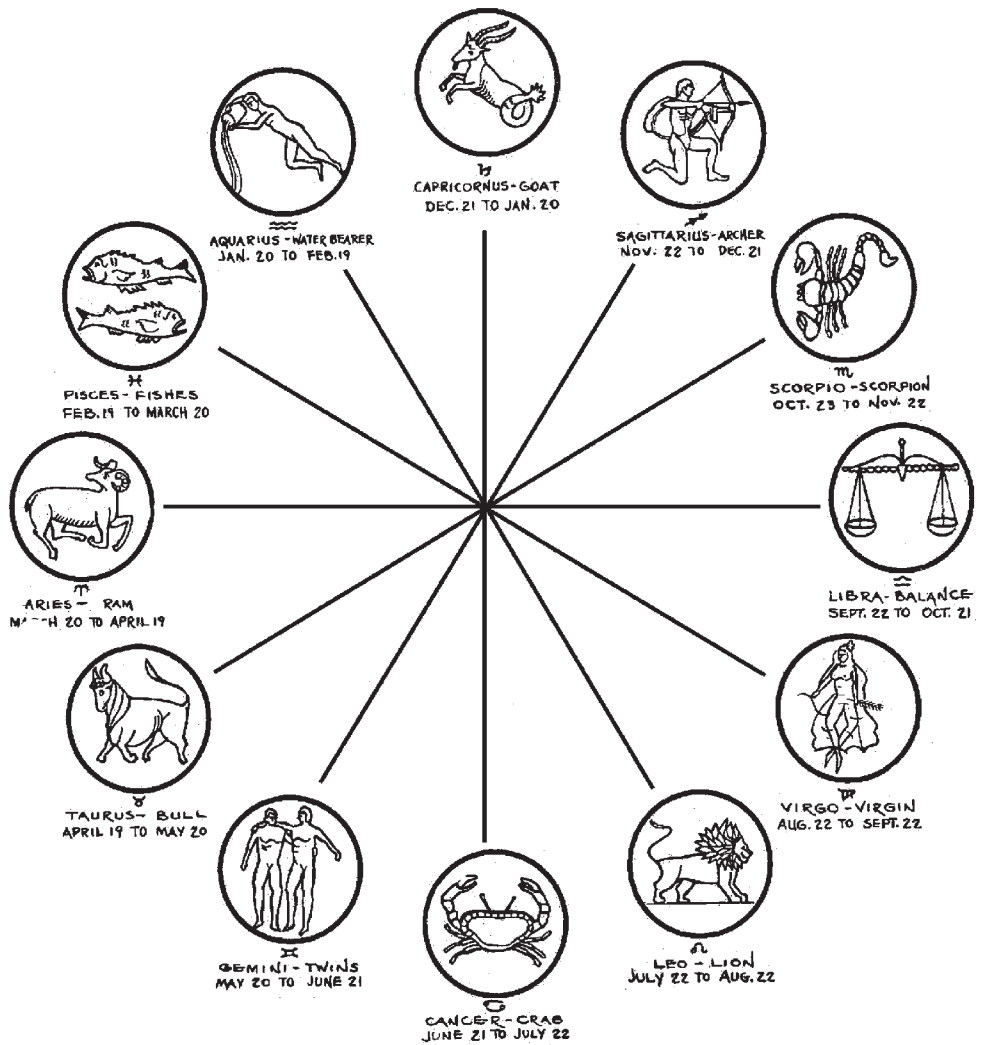

SUNDIALS



NO. 3507 GREEK SUNDIAL

16" diameter

Horizontal sundial with figures inspired from the Cave of the Winds in Athens, Greece. Bronze with Bronze gnomon.



NO. 2321 ZODIAC SUNDIAL

10" diameter

Horizontal sundial with signs of the Zodiac. Made in Bronze.



NO. 1507 SUNDIAL

10 1/2" diameter

"Time takes all but memories" horizontal sundial made out of Bronze with a Bronze gnomon.



NO. 2695 ENGLISH SUNDIAL

9 1/2" diameter

"Set me right and use me well and ye time to you will tell" horizontal Bronze English reproduction sundial with Bronze gnomon.



NO. 3605 SUNDIAL WITH PEDESTAL

Cast Stone and Bronze
Special order

NO. 2333 CUPID W/HEART SUNDIAL EXAMPLE

Special order

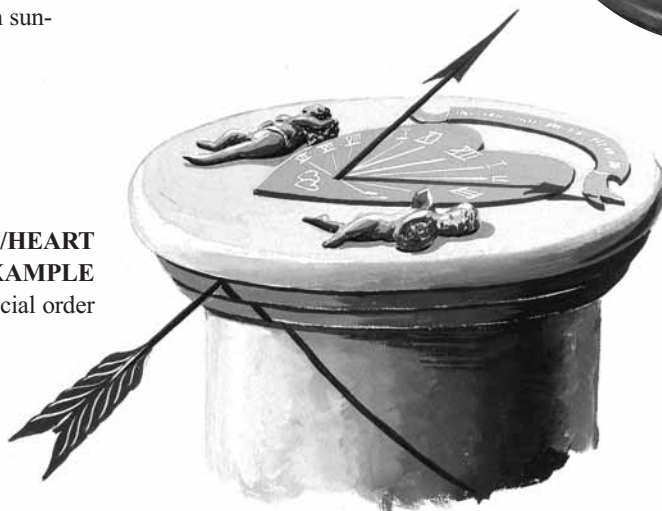



NO. 1508 SUNDIAL

7 1/2" diameter

"Grow old along with me The best is yet to be" horizontal sundial made out of Bronze with a Bronze gnomon.



NO. 2545 SUNDIAL

10" diameter

"I count none but sunny hours" horizontal sundial with winged hourglass ornament. Bronze with Bronze gnomon.



NO. 1510 SUNDIAL

9 3/4" diameter

Horizontal sundial with Bronze gnomon. Made in Lead.

Note: See pedestal pages for a good selection of pedestals to mount sundials. In many cases where the sundial might not fit a particular pedestal you might use an available adaptor.

NO. 2548 ICARUS & DAEDALUS SUNDIAL

16 1/4" diameter

Horizontal sundial featuring Icarus and Daedalus, with their wings of wax, flew too close to the sun.

Bronze with gnomon.

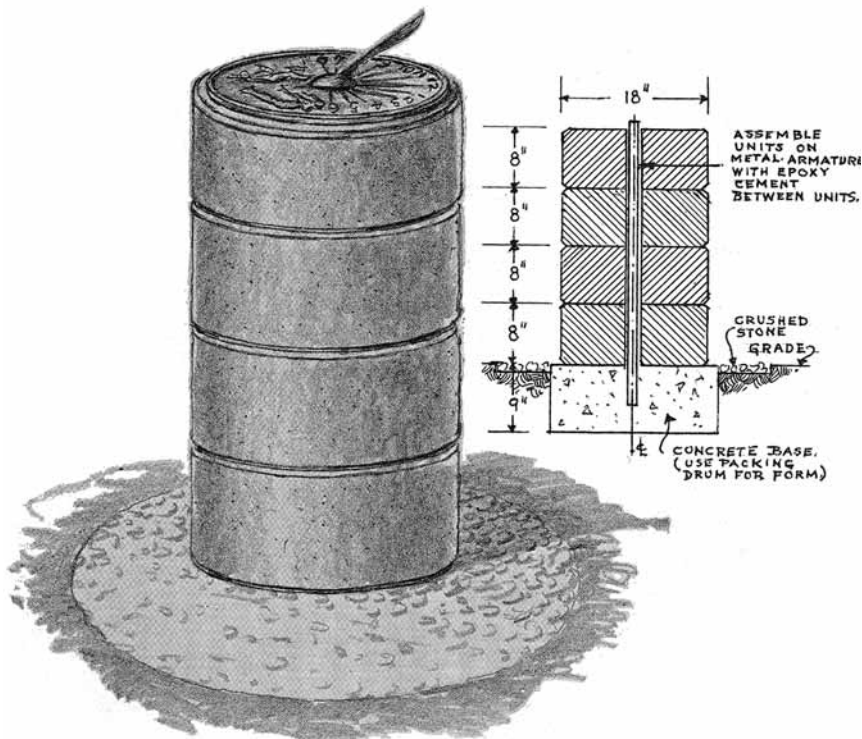

NO. 3609 PEDESTAL SECTIONS

Cast Stone

8" h X 18" diameter

This is an ideal pedestal for covering well pipes while still allowing accessibility. The illustration shows a sundial placed on a pedestal assembled of sectional plain units with chamfered edges.

The assembly is furnished with an anchor member.

NO. 2327 SUNDIAL

15 1/4" diameter

Bronze horizontal sundial furnished on a Cast Stone bezel.



SUNDIALS



NO. 2550 CELESTIAL SUNDIAL
10 1/2" diameter
Horizontal sundial showing some of the celestial sky. Bronze with Bronze gnomon.



NO. 2553 BROWNING'S POEM SUNDIAL
14" diameter
"Grow old along with me, the best is yet to be" around the outer band of this horizontal sundial. Bronze with Bronze gnomon.

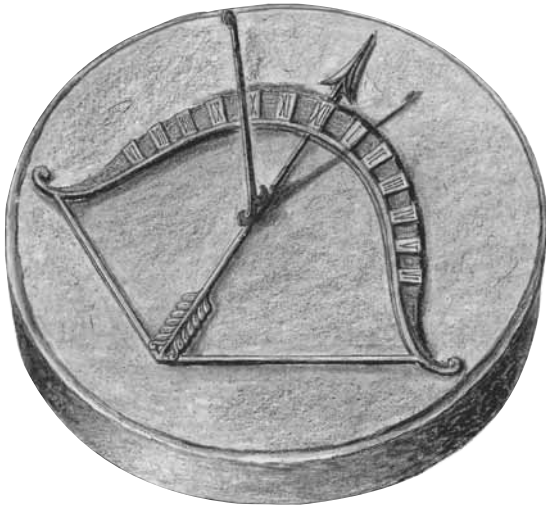

NO. 3513 BOW & ARROW SUNDIAL
18"diameter
Lead/Cast Stone



NO. 2555 SUNDIAL
11" diameter
"Grow old along with me The best is yet to be" horizontal sundial made of Bronze with a Bronze gnomon.



NO. 2602 SUNDIAL
8 5/8" diameter
"Let others tell of storms and showers I'll only mark your sunny hours."
Bronze sundial with compass rose in center.



NO. 2559 MAPLE LEAF SUNDIAL
7 1/2" X 7 1/2"
Bronze Maple leaf sundial Bronze gnomon.



NO. 2596 ENGLISH SUNDIAL
11 1/2" diameter
Horizontal sundial of English origin with signs of the Zodiac, enriched with cupids, crown and leaf. Made in Bronze.



NO. 3508 BEZEL
Cast Stone
Will accept a sundial up
to 10" diameter



NO. 3506 ZODIAC SUNDIAL
25" diameter
Horizontal Bronze sundial with signs of
the Zodiac in perimeter band. These
could be replaced with an appropriate
motto. The inner band figures are taken
from the Temple of the Winds in Athens,
Greece. Bronze with Bronze gnomon.



NO. 3519 COMPASS ROSE SUNDIAL
17 1/2" diameter

*"Serene I stand among ye flowers
And only count life's sunny hours
For me dark days do not exist
I'm a brazen-faced old optimist."*

Very ornate sundial Bronze with a compass rose
and beautiful arrangement of leaves. A very
sharp new pattern.



NO. 2563 VERTICAL SUNDIAL
7 1/2" X 7 1/2"
Wall ornament only. Bronze with
Bronze gnomon.



NO. 3539 ZODIAC SUNDIAL
28" diameter
Highly ornamented Bronze sundial with
the figures
of the Zodiac around the perimeter.



NO. 3528 EGG & DART SUNDIAL
38" diameter X 3" thick
Cast Stone massive sundial boldly and beautifully modeled and exe-
cuted. The extreme edge is carefully detailed with egg and dart
molding which frames the area where the Lead numerals are placed.
The inner wheel has twelve ornamental spokes that terminate in leaf-
like shoulders resting against the inner wheel.

SUNDIALS



NO. 3521 BAROQUE SUNDIAL
 17 1/2" diameter X 2 1/2" thick
 Cast Stone baroque sundial with leaf modeling around perimeter using Lead or Bronze numerals, which can be Gold leafed.



NO. 3520 RENAISSANCE SUNDIAL
 17 1/2" diameter X 2 1/2" thick
 Cast Stone renaissance design using laurels and bow surrounded by egg and dart molding. Lead or Bronze numerals, which can be Gold leafed.



NO. 3523 RENAISSANCE SUNDIAL
 17 1/2" diameter X 2 1/2" thick
 Cast Stone renaissance design sundial using a gentle baroque leaf design with Lead or Bronze numerals, which can be Gold leafed.

Note: See pedestal pages for a good selection of pedestals to mount sundials. In many cases where the sundial might not fit a particular pedestal you might use an available adaptor.

Please note that the sundials on this page were laid out for photographic purposes only. If you choose one of them, the numbers (as shown in the photos) may in actuality be smaller for fitting and layout purposes.



NO. 3522 SCALLOPED EDGE SUNDIAL
 17 1/2" diameter X 2 1/2" thick
 Cast Stone sundial with scalloped edge overlaid with leaf forms boldly carved in the baroque manner with Lead or Bronze numerals, which can be Gold leafed.



NO. 3524 BAROQUE SUNDIAL
 17 1/2" diameter X 2 1/2" thick
 Cast Stone baroque sundial with an adaptation of leaf ornament partially around the edge using Lead or Bronze numerals, which can be Gold leafed.



NO. 2554 HOURGLASS & PELICAN SUNDIAL

11 1/2" diameter

"A clock the time may wrongly tell, I never if the sun shines well"
horizontal sundial with winged hourglass and pelican gnomon. Bronze with Bronze gnomon.



NO. 2556 FATHER TIME SUNDIAL

11" diameter

"Grow old along with me, the best is yet to be" horizontal antique looking sundial featuring Father Time. Bronze with Bronze gnomon.



NO. 2558 NORWEGIAN SUNDIAL

13" diameter

Available in Bronze.

We suggest that a Cast Stone bezel is used to show off this beautiful sundial.



NO. 4237 FRENCH MOTTO SUNDIAL

11" diameter

"L'heure passe, l'amitie reste" "Hours pass, friendship remains"
nicely modeled horizontal sundial by Josef Kuthmayer. Decorated with ornamental dolphins facing each other and with the motto in the center. Bronze with Bronze gnomon.



NO. 3540 SPANISH SUNDIAL

14"h x14"w X 14"l

Reproduction in Cast Stone from an old capital that resided in an old monastery. The numerals are Lead, Bronze or Stainless Steel and gnomon is Bronze.



NO. 3583 COMBINED SUNDIAL AND PEDESTAL

21 1/2"h.

Top 13"x 13".

Base 11"x 11"

Reproduced in Cast Stone by using an old capital and an old base, and placing numerals and gnomon on the top.

SUNDIALS



NO. 4672 ELEVATED ARRANGEMENT USING NO. 2324 SUNDIAL

An elevated arrangement using two steps, a pedestal, and a fine sundial make a very impressive setting. The sundial, No. 2324, is available in Lead or Bronze. It is a very unusual sundial which tells the story of the race between the tortoise and hare. Other sundials can be substituted. The pedestal is No.1077 and is 28" high which makes it very nice for children to view. The first step is 64" diameter, and the second step is approximately 38 1/2" diameter.



NO. 2939 PEACOCK SUNDIAL

6"h X 14 1/2"diameter
Horizontal Lead with Lead numerals.
Very rare design.



NO. 2324 TORTOISE & HARE SUNDIAL

11" diameter
Horizontal sundial. Tells the story of the tortoise and hare. Bronze with Bronze gnomon. Also available in Lead.



NO. 2307 DUCK HEAD & CATTAIL SUNDIAL

14" diameter
Unique design of a horizontal sundial. Cast Stone bezel with Bronze duck head and cattail gnomon.

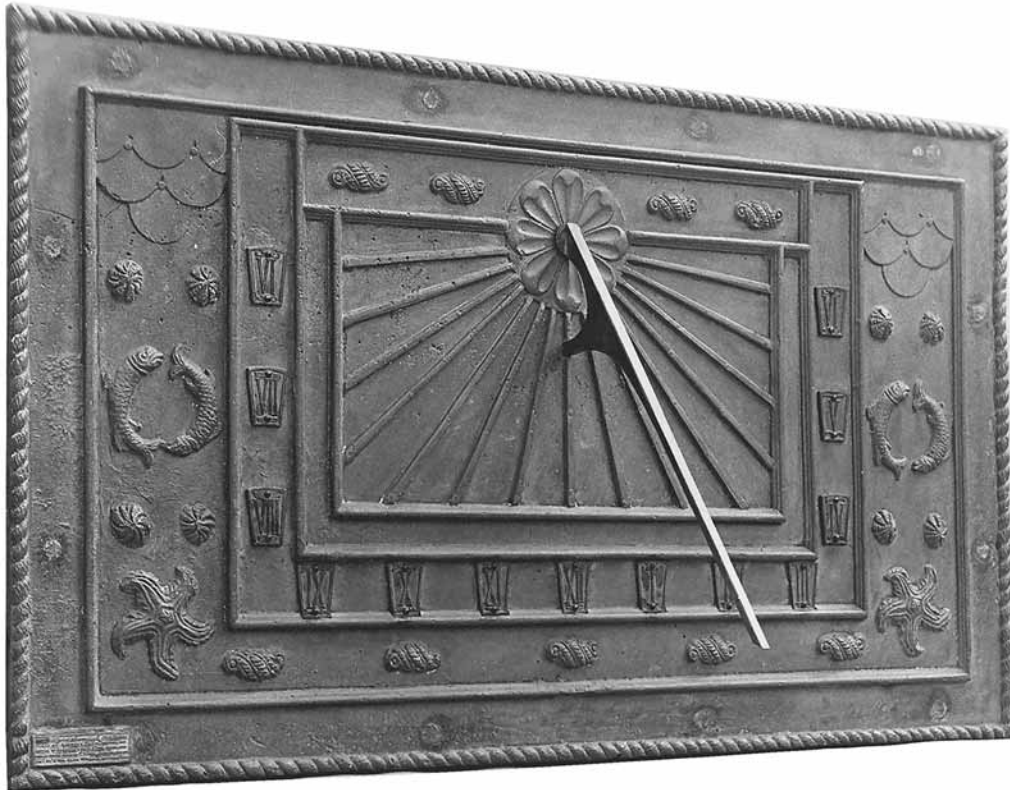

NO. 2325 WALL SUNDIAL
43 1/2" X 25 1/2"
Wall sundial for direct south reading only. Probably laid out for 40° north latitude. From this design we can make a pattern to suit your specific needs. Numerals can be changed.



NO. 2326 MASSIVE WALL SUNDIAL
47 1/4" X 23 5/8"

Bronze wall sundial. Note that this is laid out for a vertical declining wall. Kindly inquire.



NO. 2549 ENGLISH WALL SUNDIAL
11 3/4" w X 15 1/4" h
Bronze wall sundial. Originating from Hope and Sons, Birmingham, England.

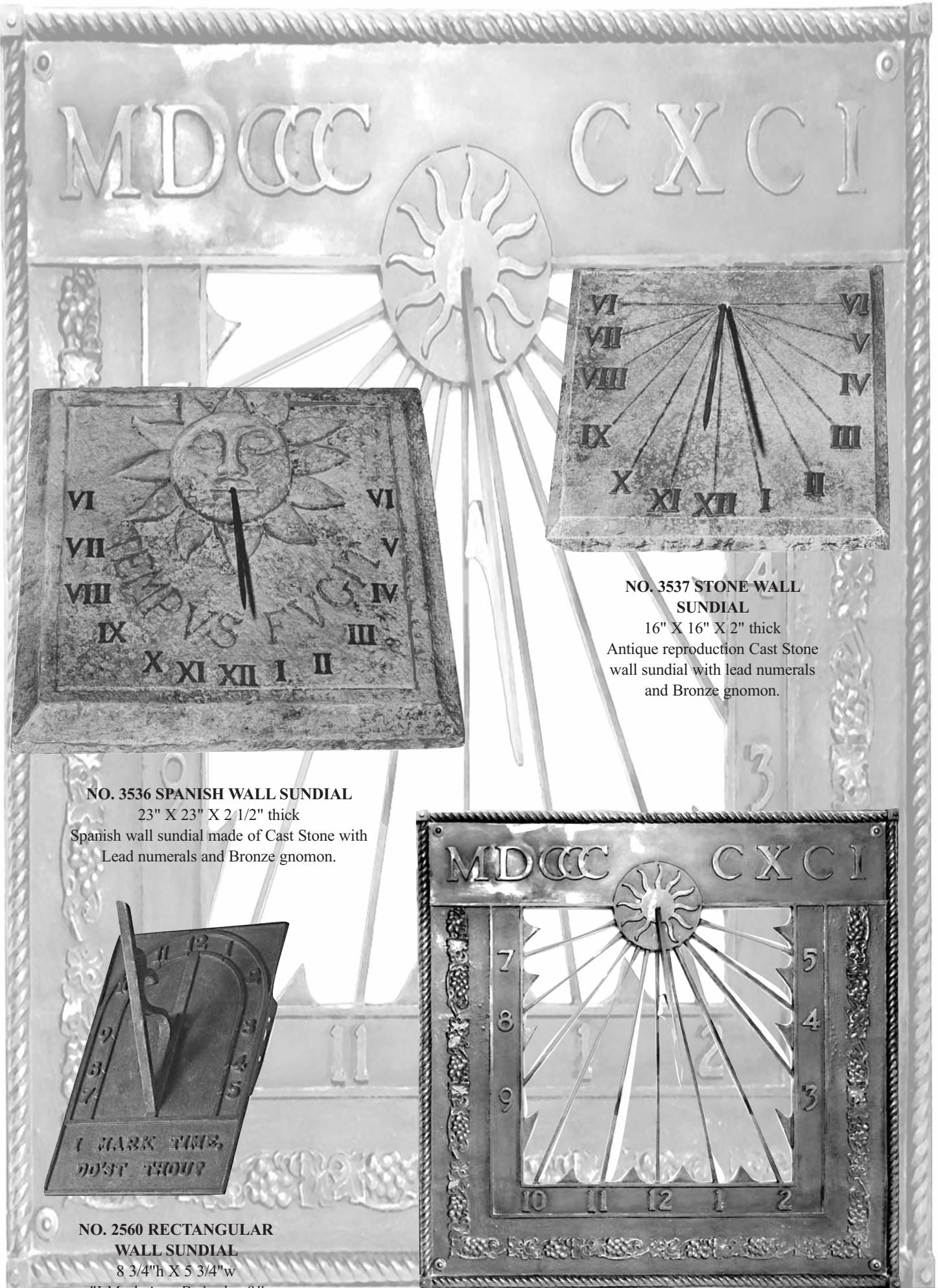

NO. 3536 SPANISH WALL SUNDIAL

23" X 23" X 2 1/2" thick
Spanish wall sundial made of Cast Stone with
Lead numerals and Bronze gnomon.

**NO. 3537 STONE WALL
SUNDIAL**

16" X 16" X 2" thick
Antique reproduction Cast Stone
wall sundial with lead numerals
and Bronze gnomon.

**NO. 2560 RECTANGULAR
WALL SUNDIAL**

8 3/4" h X 5 3/4" w
*"I MARK TIME,
DO'ST THOU?"*
Horizontal Bronze sundial
with Bronze gnomon.

NO. 2330 WALL SUNDIAL

36" X 36"
Bronze sundial with fine detail of grape design. Date at top can
be changed and roman numerals are used.



SUNDIAL SETTING INSTRUCTIONS

THESE INSTRUCTIONS ARE FOR INSTALLING A HORIZONTAL OR AN ARMILLARY SUNDIAL.

Select the site. The best position would be that is placed in direct sunlight all day. The base on which the sundial rests must be level.
Note: These instructions are for the ideal installation.

If you are starting from scratch, say in the middle of a lawn or garden, with no existing foundation, then you should dig a hole about as deep as required for house footings, to get below maximum depth of frost or to compensate for unstable soil conditions. Fill in this hole with concrete or put in a form such as Sonotube, backfill against the form and fill the form with concrete. Noting that later you will need a hole in this foundation for the pedestal's anchor to go in, now is the time to plan this so you will not have to drill it in later. Take a cardboard tube, the core of a roll of toilet paper or paper towel, and stuff it with newspaper. Tape the ends and around the tube, from end to end, with scotch tape. As you fill the form with concrete, Sakrete or equivalent, place the stuffed cardboard tube in the center, or wherever the anchor is in the pedestal, and continue to fill around it. The object is that the cardboard tube will make a vertical hole in the foundation. The top of the tube should be even with the top of the concrete. Smooth the top of the concrete. Go away and come back tomorrow.

Now dig the cardboard tube out of its position at the top of the foundation. Get all the tape out. Prepare a mix of cement mortar. Fill the hole completely and cover the top of the foundation with approximately 1" thick of mortar. With the anchor screwed into the threaded insert at the bottom of the pedestal, pick up the pedestal, by hand or machine as necessary, and place it on the foundation with the anchor in the hole. As you are setting the pedestal, have a level handy so you can level and plumb the pedestal. Wiggle the pedestal down into the mortar, keeping it level and plumb. Clean up the mortar that squeezed out. If it got onto the outside of the pedestal, sponge off with water. Finish the joint nicely. Save the mortar if you want to use it for the next step.

Of course, if you have a solid surface on which to mount your pedestal you need only the latter part of the preceding paragraph.

The sundial will be provided with anchors for securing it to the base, perhaps a pedestal. Before you begin to install the sundial you should determine True North if you wish for an accurate installation. True North can be found by using magnetic north and adding or subtracting (as the case may be) compass deviation. For very large installations, you may wish to employ a surveyor to lay out true north. To install the sundial, either make a template of the anchor from the bottom of the sundial or install the anchors and place the dial on the pedestal and mark around them. Drill the holes if they don't exist. If you use the mortar, then drill the holes about double the diameter as the anchors. If you use epoxy, drill only large enough to get the anchors in and only deep enough to do the job. Fill the holes with mortar, a bit soupy and extra cement added, or epoxy. A non shrinking cement grout for machinery is very good to use. Careful not to get this all over the pedestal. If you do, wash with water right NOW. Of course, you have to make sure that the sundial will fit and all is OK to proceed. Install the sundial onto the pedestal making sure it seats all the way down. You're DONE!!

More complete instructions are available, but these should be enough for most installations.



SUNDIALS



NO. 3458 CHARTRES ANGEL WITH SUNDIAL

Lead or Bronze, 48" h
 This figure is an exact reproduction of the figure in the Cathedral at Chartres. A reproduction of this figure is now in the Louvre in Paris. It is 48" tall overall. The lead base is 9 1/2" deep by 11 1/2" wide, and the wings are 36" from top to bottom. The way this piece is designed, it must face south to southwest. It should be used with a pedestal. Pedestal sold separately.



NO. 2400 CUPID WITH SUNDIAL OR BIRDFEEDER

30 1/2" h
 Available in Lead or Bronze.



NO. 674D SERVER WITH SUNDIAL

Lead, 51" h
 Available in Bronze.



NO. 2210 CUPID WITH SUNDIAL

30 1/2" h
 Available in Lead or Bronze.
 Lead figure with Bronze sundial or all Bronze.



NO. 2446 CUPID WITH STONE & BRONZE SUNDIAL

Lead, 30 1/2" h
 Available in Bronze.



NO. 2107 DIRECTIONAL MARKER
4" diameter
Solid Bronze closed pattern.

Note: See pedestal pages for a good selection of pedestals to mount sundials. In many cases where the sundial might not fit a particular pedestal you might use an available adaptor.

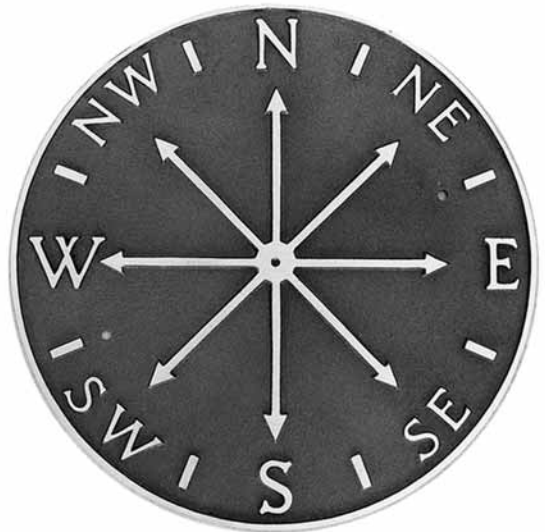

NO. 2691 COMPASS
Available in three sizes:
5 3/4", 7 5/8" or 11 3/4" diameter
Bronze compass.

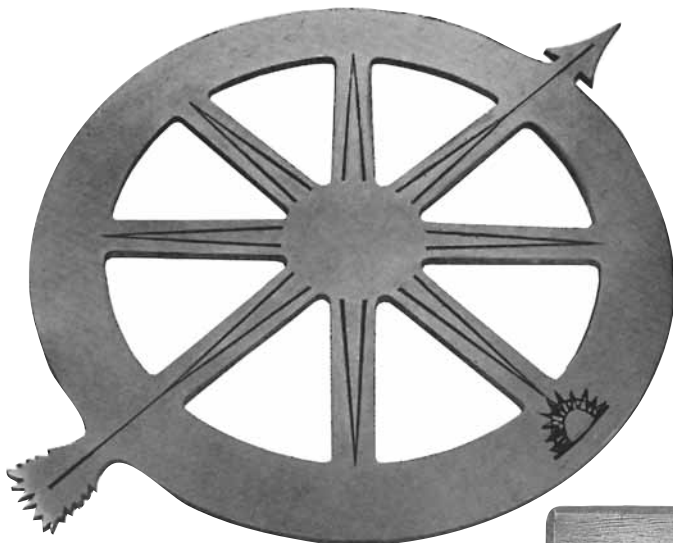

NO. 2703 COMPASS
Available in two sizes:
14" or 21" diameter
Bronze compass of unusual design with an engraved rising sun.



NO. 2693 DIRECTIONAL MARKER
6 3/4" diameter
Lead or Bronze directional marker. Should be set in concrete, either precast or cast in place.

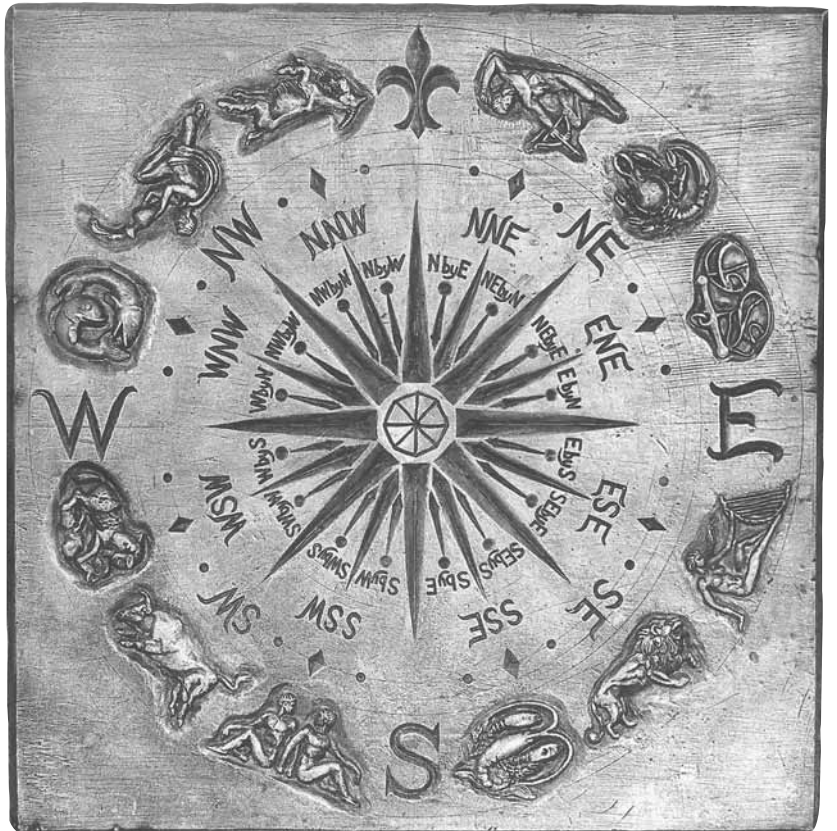

NO. 1310 ORNAMENTAL COMPASS
37" X 37" X 3" thick
Cast Stone of highly ornamental design.

DIRECTIONAL MARKERS

NO. 4502 DIRECTIONAL MARKER
25" diameter
Bronze directional marker with outer
zodiac ring.



NO. 3466 DIRECTIONAL MARKER
23 1/2" diameter
Solid Bronze directional marker with bold
modeling of the four seasons.



NO. 2696 DIRECTIONAL MARKER
10 1/8" diameter
Bronze directional marker with symbols of
the Zodiac and the Maltese Cross.



**NO. 2429 GREEK
DIRECTIONAL
MARKER**
12 3/4" diameter
Bronze directional marker
beautifully modeled by Josef
Kuthmayer. The traditional
Greek figures of the four
winds from the Temple of
the Winds, Athens, Greece,
are chiseled in very sharp
detail.



**NO. 2605 DIRECTIONAL
MARKER**
11 1/2" diameter
Solid Bronze directional marker.



**NO. 4556 DIRECTIONAL
MARKER**
16" diameter
Bronze directional marker with
outer dedicatory band.



NO. 2670 DIRECTIONAL MARKER

28" diameter

This Cast Stone directional marker is covered with the signs of the Zodiac and circling this beautiful representation of the sun.



NO. 4503 NYC DIRECTIONAL MARKER

32" diameter

Bronze directional marker designed by Chris Crowley of the City of New York Department of Parks and Recreation. First used in ST. Catherine's Park, New York City.

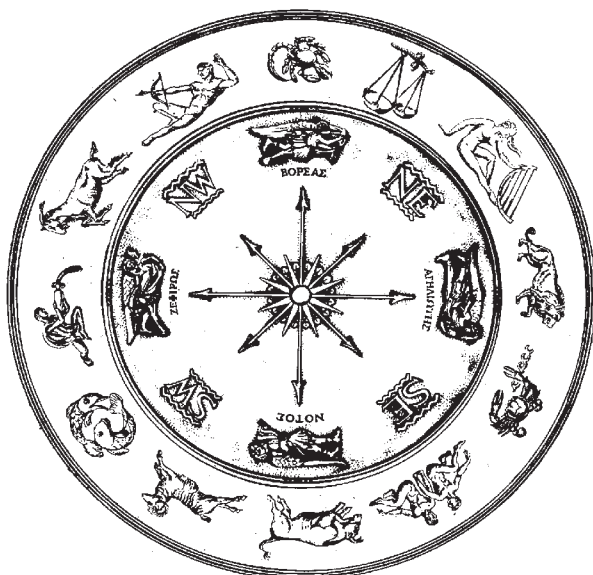

NO. 4569 DIRECTIONAL MARKER

Bronze

20" diameter

Directional marker with outer zodiac ring and No. 2429 centerpiece. This gives the observer both the symbols of the wind from the Temple of the Winds and the signs of the Zodiac.

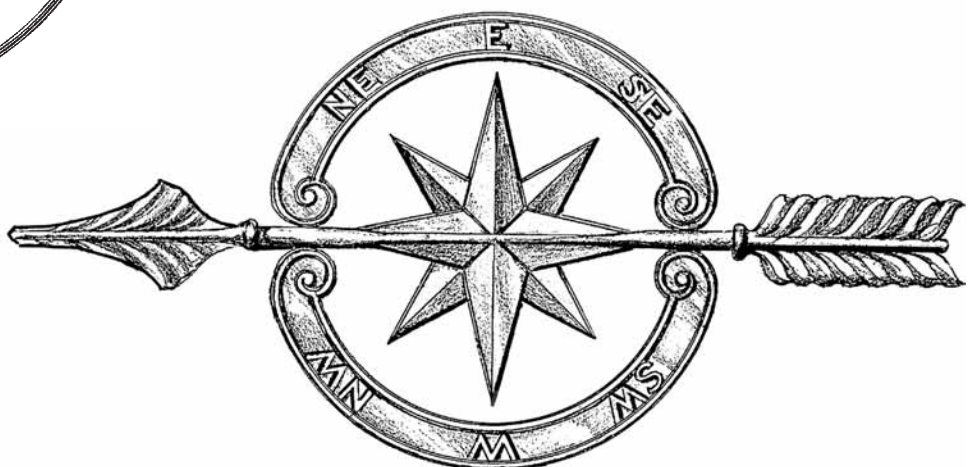

NO. 4198 DIRECTIONAL MARKER

16" diameter

30" - 36" long from point to fletching.

Bronze

Note: See pedestal pages for a good selection of pedestals to mount sundials. In many cases where the sundial might not fit a particular pedestal you might use an available adaptor.

SUNDIAL EXAMPLES

NO. 3457 ARMILLARY SUNDIAL

48" diameter

This is an example of one of the more unusual styles of an armillary type sundial with the equatorial ring mounted on a trunnion with a horizontal ring. This provides for in-the-field accuracy. The legs are of hand-forged twisted Iron, and the horizontal ring is of hand-forged Iron with Lead Zodiac figures mounted on it. Must be mounted in a Cast Stone pedestal.

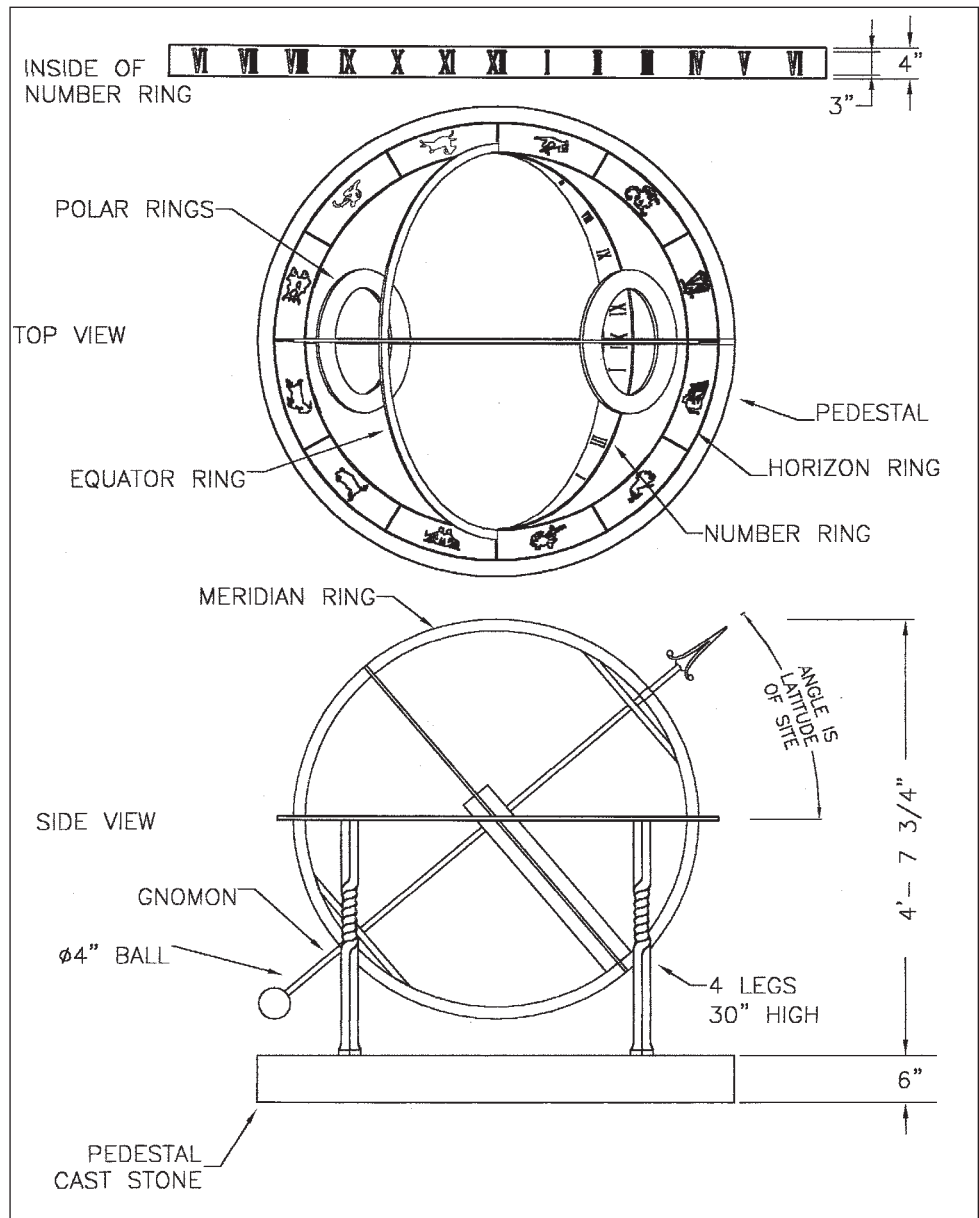

VI VII VIII IX X XI XII I II III IV V VI

INSIDE OF EQUATOR RING

♋ ♌ ♍ ♎ ♏ ♐ ♑ ♒ ♓

OUTSIDE OF EQUATOR RING

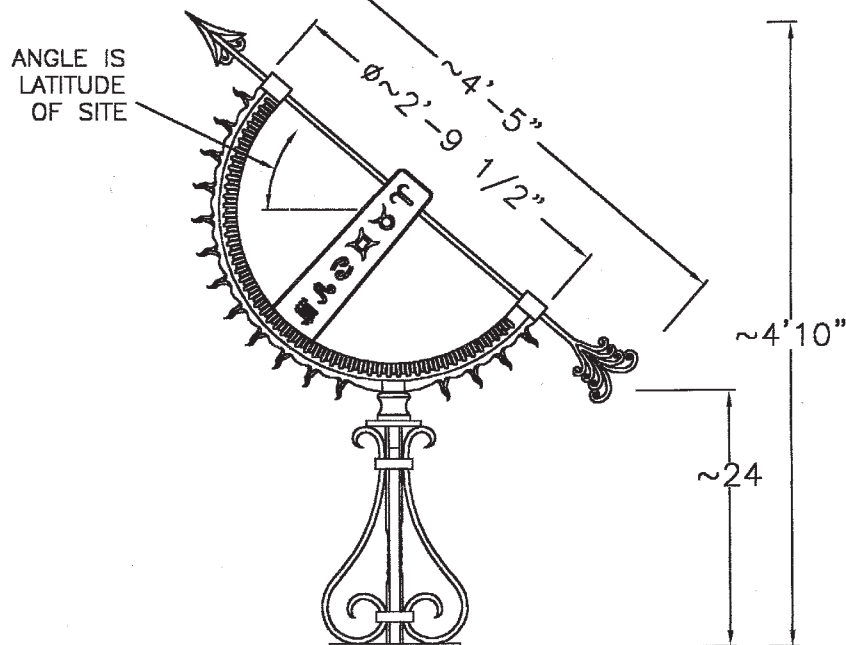

NO. 3428 HEMISPHERICAL SUNDIAL

Bronze

58" h overall with a 53" length from arrowhead to fletching.

This is an example of the schematic structure of one of our more attractive pieces.